

13. EXPLODED VIEWS AND PARTS LIST

13-1. Indoor Unit

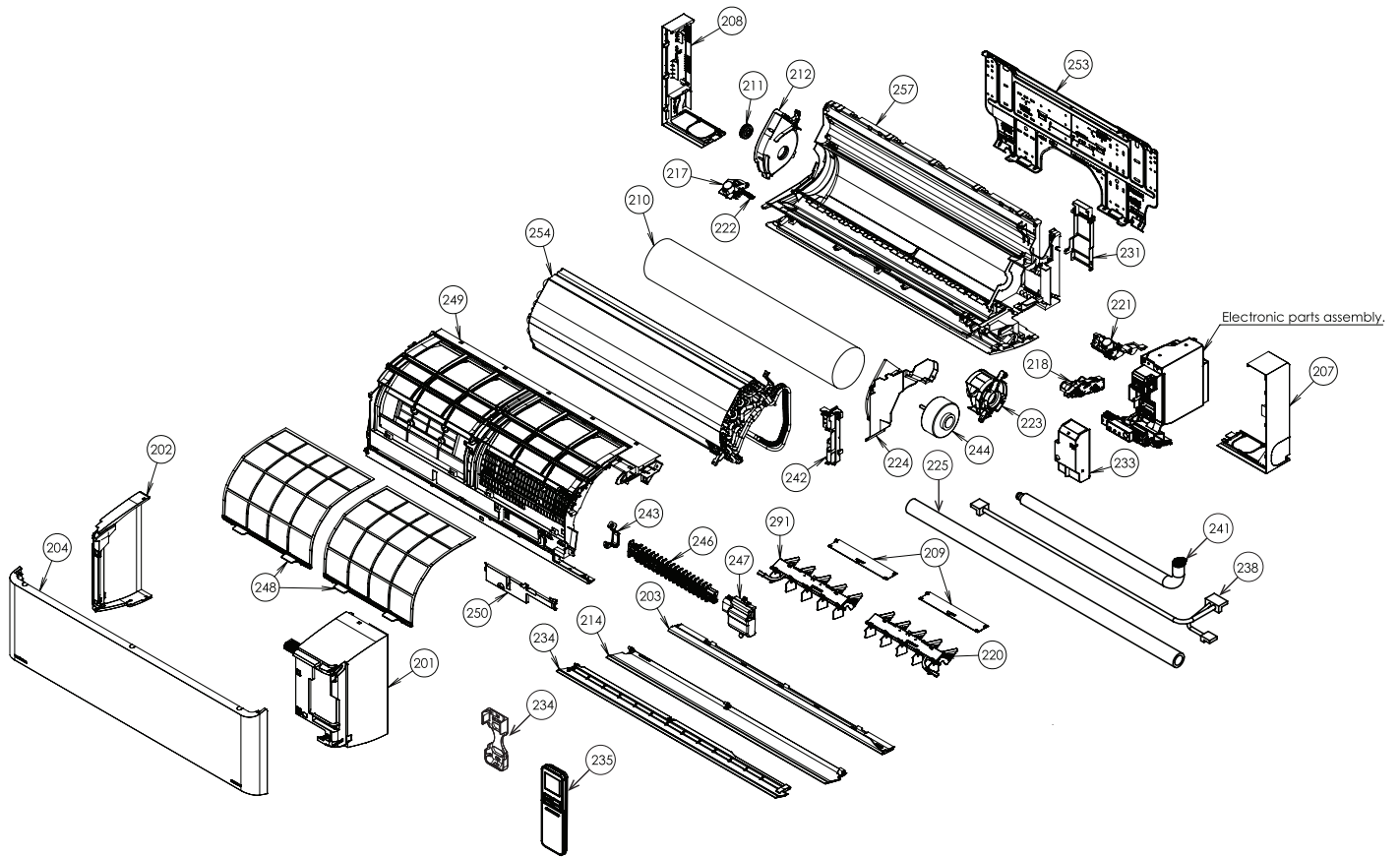

Location No.	Part No.	Description	Location No.	Part No.	Description
201	43T00731	ASM-PANEL(R)-S	225	43T11331	PIPE-SHIELD
202	43T00732	ASM-PANEL(L)-S	231	43049799	HOLDER-PIPE
203	43005871	ASM-PANEL(AOLT)	233	43T62352	ASM-COVER-CONN
204	43T09545	ASM-AINL-S	234	43T83305	HOLDER, REMOTE CONTROL
207	43T02306	ASM-BUSH-BODY(R)	235	43T66376	WIRELESS REMOCO
208	43T02307	ASM-BUSH-BODY(L)	238	4306A194	CORD-MOTOR(LV)
209	43T04351	ASM-BODY-BUSH(DN)	241	43T70314	HOSE-DRAIN
210	43020380	ASM-FAN-CF(CE110)	242	43T63355	ASM-EARTH
211	43022466	ASM-BEAR-MOLD	243	43080658	HOLD-ION
212	43022472	BASE-BEARING	244	43T21421	FAN MOTOR
213	43022473	LOUVER-HR(FR)	246	43T80345	ASM-ION-S
214	43022475	LOUVER-HR(BK)	247	43T80347	ASM-SUP-HP-S
217	4302C106	MOTOR-LOUVER	248	43T80342	FILTER-AIR
218	43T2D301	ASM-SUB-GEAR(LV)-S	249	43T08428	ASM-FRAME-S
219	43T09503	ASM-LOUVER-VT	250	43T08429	ASM-COVER-WIFI
220	43T09504	ASM-LOUVER-VT	252	43082298	PLATE-INST
221	43T2D302	ASM-GEAR(LV)	254	43T44625	ASM-CYCLE-REF(10k,13k)
222	4302D021	ASM-ARM(L)	254	43T44626	ASM-CYCLE-REF(16k)
223	43039404	BAND-MOTOR	257	43T03411	ASM-BODY-BACK
224	43039406	ASM-COV-MOTOR			

13-2. Indoor Unit (E-Parts Assy)

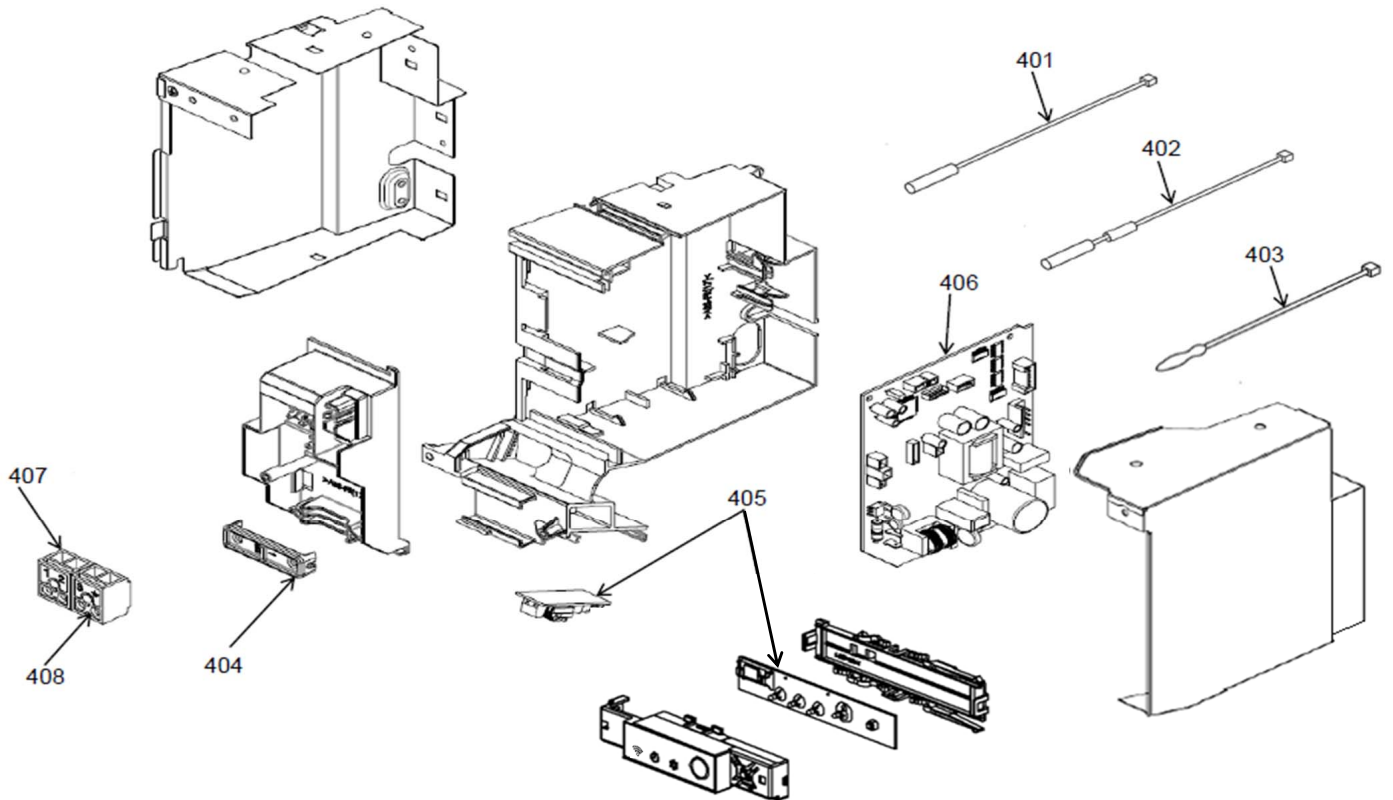

Location No.	Part No.	Description	Location No.	Part No.	Description
401	43T50324	SENSOR; HEAT EXCHANGER	406	43T6W349	PC BOARD (10k)
402	43T50320	SENSOR; HEAT EXCHANGER	406	43T6W350	PC BOARD (13k)
403	43T50355	TEMPERATURE SENSOR	406	43T6W351	PC BOARD (16k)
404	43T62340	CORD-CLAMP	407	43T60378	TERMINAL
405	43T6V469	PC BOARD ASSY:WRS-LED	408	43T60417	TERMINAL

TOSHIBA CARRIER (THAILAND) CO., LTD.

**144/9 MOO 5, BANGKADI INDUSTRIAL PARK, TIVANON ROAD, TAMBOL BANGKADI,
AMPHUR MUANG, PATHUMTHANI 12000, THAILAND.**