

# TOSHIBA

## Universal Smart X Safety Precautions Original Owner's Manual

### Air-Cooled Chiller

### Model Name: RUAGP Series

- Thank you very much for purchasing this Toshiba heat pump unit. Please read this instruction manual carefully before using the unit. Be sure to obtain the "Instruction manual" and "Installation manual" from constructor or dealer. Request to constructor or dealer; Please clearly explain the contents of this instruction manual and hand over it.
- This unit is not intended for use by person (including children) with reduced physical, sensory or mental capabilities, or lack of experience and knowledge, unless they have been given supervision or instruction concerning use of the unit by a person responsible for their safety.
- Fluorocarbon must be recovered in accordance with the local laws and regulations when the product is repaired or thrown away. Type and volume of refrigerant and conversion values for CO<sub>2</sub> are listed.
- Keep this manual after you finish reading it.
- Please read carefully through these instructions that contain important information which complies with the "Machinery Directive 2006/42/EC", and ensure that you understand them.
- This unit is only for industrial uses. And this unit is not usable in residential use.

**Toshiba Carrier Corporation**

Original instructions  
30KQA060-01ISE

## Contents

Safety Precautions .....	4
List of Equipment • Configuration of Heat Pump.....	9
Dimensional drawings (Integrated inverter pump, pumpless) .....	11
Control box layout diagram .....	14
High EER Type Drainage .....	15
Module Controller.....	18
Unit Controller .....	35
Unit Controller (with pressure display function).....	39
Main Functions.....	42
Control Flow .....	47
Refrigerant piping drawings .....	62
Operating Standard and Operating Range.....	64
Component Rating .....	67
High EER Type.....	68
Maintenance and Inspection .....	71
Water Heat Exchanger Maintenance .....	75
Pump Maintenance .....	76
Water Quality Management.....	77
Precautions When Operation Is Stopped .....	78
Troubleshooting .....	79

## Original instructions

### Generic Denomination : Heat Pump Unit





#### Definition of Qualified Installer or Qualified Service Person

The heat pump unit (called "unit" hereafter) must be installed, maintained, repaired and removed by a qualified installer or qualified service person. When any of these jobs is to be done, ask a qualified installer or qualified service person to do them for you. A qualified installer or qualified service person is an agent who has the qualifications and knowledge described in the table below.

Agent	Qualifications and knowledge which the agent must have
Qualified installer	<ul style="list-style-type: none"> <li>● The qualified installer is a person who installs, maintains and removes the units made by Toshiba Carrier Corporation. He or she has been trained to install, maintain and remove the units made by Toshiba Carrier Corporation or, alternatively, he or she has been instructed in such operations by an individual or individuals who have been trained and is thus thoroughly acquainted with the knowledge related to these operations.</li> <li>● The qualified installer who is allowed to do the electrical work involved in installation and removal has the qualifications pertaining to this electrical work as stipulated by the local laws and regulations, and he or she is a person who has been trained in matters relating to electrical work on the units made by Toshiba Carrier Corporation or, alternatively, he or she has been instructed in such matters by an individual or individuals who have been trained and is thus thoroughly acquainted with the knowledge related to this work.</li> <li>● The qualified installer who is allowed to do the refrigerant handling and piping work involved in installation and removal has the qualifications pertaining to this refrigerant handling and piping work as stipulated by the local laws and regulations, and he or she is a person who has been trained in matters relating to refrigerant handling and piping work on the units made by Toshiba Carrier Corporation or, alternatively, he or she has been instructed in such matters by an individual or individuals who have been trained and is thus thoroughly acquainted with the knowledge related to this work.</li> <li>● The qualified installer who is allowed to work at heights has been trained in matters relating to working at heights with the units made by Toshiba Carrier Corporation or, alternatively, he or she has been instructed in such matters by an individual or individuals who have been trained and is thus thoroughly acquainted with the knowledge related to this work.</li> </ul>
Qualified service person	<ul style="list-style-type: none"> <li>● The qualified service person is a person who installs, repairs, maintains and removes the units made by Toshiba Carrier Corporation. He or she has been trained to install, repair, maintain and remove the units made by Toshiba Carrier Corporation or, alternatively, he or she has been instructed in such operations by an individual or individuals who have been trained and is thus thoroughly acquainted with the knowledge related to these operations.</li> <li>● The qualified service person who is allowed to do the electrical work involved in installation, repair and removal has the qualifications pertaining to this electrical work as stipulated by the local laws and regulations, and he or she is a person who has been trained in matters relating to electrical work on the units made by Toshiba Carrier Corporation or, alternatively, he or she has been instructed in such matters by an individual or individuals who have been</li> </ul>

	<p>trained and is thus thoroughly acquainted with the knowledge related to this work.</p> <ul style="list-style-type: none"><li>● The qualified service person who is allowed to do the refrigerant handling and piping work involved in installation, repair and removal has the qualifications pertaining to this refrigerant handling and piping work as stipulated by the local laws and regulations, and he or she is a person who has been trained in matters relating to refrigerant handling and piping work on the units made by Toshiba Carrier Corporation or, alternatively, he or she has been instructed in such matters by an individual or individuals who have been trained and is thus thoroughly acquainted with the knowledge related to this work.</li><li>● The qualified service person who is allowed to work at heights has been trained in matters relating to working at heights with the units made by Toshiba Carrier Corporation or, alternatively, he or she has been instructed in such matters by an individual or individuals who have been trained and is thus thoroughly acquainted with the knowledge related to this work.</li></ul>
--	--

**Warning indications on the heat pump unit**

Warning indication	Description		
 <table border="1" data-bbox="277 327 730 573"> <tr> <td data-bbox="277 327 730 405" style="text-align: center;"><b>WARNING</b></td> </tr> <tr> <td data-bbox="277 405 730 573"> <b>ELECTRICAL SHOCK HAZARD</b>                      Disconnect all remote electric power supplies before servicing.                 </td> </tr> </table>	<b>WARNING</b>	<b>ELECTRICAL SHOCK HAZARD</b> Disconnect all remote electric power supplies before servicing.	<p><b>WARNING</b>  <b>ELECTRICAL SHOCK HAZARD</b>                      Disconnect all remote electric power supplies before servicing.</p>
<b>WARNING</b>			
<b>ELECTRICAL SHOCK HAZARD</b> Disconnect all remote electric power supplies before servicing.			
 <table border="1" data-bbox="277 611 730 857"> <tr> <td data-bbox="277 611 730 689" style="text-align: center;"><b>WARNING</b></td> </tr> <tr> <td data-bbox="277 689 730 857">                     Moving parts.                      Do not operate unit with grille removed.                      Stop the unit before the servicing.                 </td> </tr> </table>	<b>WARNING</b>	Moving parts. Do not operate unit with grille removed. Stop the unit before the servicing.	<p><b>WARNING</b>                      Moving parts.                      Do not operate unit with grille removed.                      Stop the unit before the servicing.</p>
<b>WARNING</b>			
Moving parts. Do not operate unit with grille removed. Stop the unit before the servicing.			
 <table border="1" data-bbox="277 936 730 1182"> <tr> <td data-bbox="277 936 730 1014" style="text-align: center;"><b>CAUTION</b></td> </tr> <tr> <td data-bbox="277 1014 730 1182">                     High temperature parts.                      You might get burned when removing this panel.                 </td> </tr> </table>	<b>CAUTION</b>	High temperature parts. You might get burned when removing this panel.	<p><b>CAUTION</b>                      High temperature parts.                      You might get burned when removing this panel.</p>
<b>CAUTION</b>			
High temperature parts. You might get burned when removing this panel.			
 <table border="1" data-bbox="277 1272 730 1518"> <tr> <td data-bbox="277 1272 730 1350" style="text-align: center;"><b>CAUTION</b></td> </tr> <tr> <td data-bbox="277 1350 730 1518">                     Do not touch the aluminum fins of the unit.                      Doing so may result in injury.                 </td> </tr> </table>	<b>CAUTION</b>	Do not touch the aluminum fins of the unit. Doing so may result in injury.	<p><b>CAUTION</b>                      Do not touch the aluminum fins of the unit.                      Doing so may result in injury.</p>
<b>CAUTION</b>			
Do not touch the aluminum fins of the unit. Doing so may result in injury.			

# Safety Precautions

The manufacturer shall not assume any liability for the damage caused by not observing the description of this manual.

## **WARNING**

### **General**

- Carefully read Instruction Manual before starting the unit. There are many important things to keep in mind for daily operation. Otherwise, falling down of the unit may occur, or the unit may cause noise, vibration or water leakage.
- Ask for installation to be performed by the dealer or a professional. Only a qualified installer (\*1) is able to install a unit. If a non-qualified person installs a unit, it may result in problems such as fire, electric shock, injury, water leakage, noise and/or vibration.
- Take measures to prohibit persons other than those concerned from entering the area where the unit is installed.
- Be sure to use the company-specified products for the separately purchased parts. Use of non-specified products may result in fire, electric shock, water leakage, etc. Have the installation performed by a professional.
- Do not use any refrigerant different from the one specified for complement or replacement. Otherwise, abnormally high pressure may be generated in the refrigeration cycle, which may result in a failure or explosion of the product or an injury to your body. The refrigerant used by this unit is the R32.
- Before opening the service panel of the unit, set the circuit breaker to the OFF position, lock the circuit breaker in the OFF position, place a "work in progress" sign near the circuit breaker, and wait for 10 minutes to discharge the capacitors completely. Failure to set the circuit breaker to the OFF position and wait for 10 minutes to discharge the capacitors may result in electric shocks through contact with the interior parts. Only a qualified installer (\*1) or qualified service person (\*1) is allowed to remove the service panel of the unit and do the work required.
- Use of a stand more than 50 cm high to clean the body of the unit or to carry out other such jobs constitutes working at heights. Due to the danger of falling off the stand and injuring yourself while working at heights, this kind of work should not be done by unqualified individuals. When this kind of work must be carried out, do not do it yourself but ask a qualified installer or a qualified service person to do it for you.
- Do not touch the aluminum fin of the unit. You may injure yourself if you do so. If the fin must be touched, do not touch it yourself but contact a qualified installer or a qualified service person.
- Do not climb onto or place objects on top of the unit. You may fall or the objects may fall off of the unit and result in injury.
- Do not disassemble, modify, repair or move the product yourself. Doing so may cause fire, electric shock, injury or water leaks. Ask a qualified installer or qualified service person to do any repairs or to move the product.
- Using FlashAir make any other machines having problem, deattached FlashAir at once
- Carefully read Instruction Manual before starting the unit. There are many important things to keep in mind for daily operation.

### **Transportation and storage**

- When transporting the unit, wear shoes with protective toe caps, injury protection gloves with non-slip function and long sleeved working clothes.
- When transporting the unit, do not take hold of the packing materials. You may injure yourself if the packing materials should break.

- When storing or transporting the unit, heed the precautions written on the packages. Failure to heed the precautions may cause the unit to be damaged.
- You shall ensure that the unit is transported in stable condition. If you find any part of the product broken, contact your dealer.
- When storing or transporting the unit, be sure to place the ambient temperature of the unit within a range of -20 to +60°C.

### **Selection of installation location**

- If you install the unit in a small and/or closed room, take appropriate measures to prevent the refrigerant from exceeding the limit concentration even if it leaks. Consult the dealer from whom you purchased the unit when you implement the measures. Accumulation of highly concentrated refrigerant may cause an oxygen deficiency accident.
- Do not install in a location where flammable gas may leak. If the gas should leak and accumulate around the unit, it may ignite and cause a fire.
- Do not provide with permanent scaffolds to easily access to the fans on the top of the unit. There is a risk of an injury due to the rotating parts.
- Do not place any combustion appliance in a place where it is directly exposed to the wind of unit, otherwise it may cause imperfect combustion.
- Places where the operation sound of the unit may cause a disturbance. (Especially at the boundary line with a neighbor, install the unit while considering the noise.)

### **Installation**

- Follow the instructions in the Installation Manual to install the unit. Failure to follow these instructions may cause the product to fall down or topple over or give rise to noise, vibration, water leakage or other failure.
- Confirm that the unit is fixed on the base. Otherwise, falling down of the unit or other accidents may occur.
- After the installation work has been completed, have the installer explain about the circuit breaker positions. In the event that error has occurred in the unit, set the circuit breaker to the OFF position, and contact a service person.

### **Refrigerant piping**

- Only a qualified installer (\*1) or qualified service person (\*1) is allowed to carry out the welding work of the unit. Under no circumstances must this work be done by an unqualified individual since failure to carry out the work properly may result in refrigerant leaks.
- Using the service port to charge and discharge the refrigerant. In case of using the other, it causes overcharge, leak, uncontrollable the refrigerant and unsafe connection and disconnection.

### **Electrical wiring**

- Only a qualified installer (\*1) or qualified service person (\*1) is allowed to carry out the electrical work of the unit. Under no circumstances must this work be done by an unqualified individual since failure to carry out the work properly may result in electric shocks and/or electrical leaks.
- Confirm that earthing is performed correctly.

### **Water piping**

- Only a qualified installer (\*1) or qualified service person (\*1) is allowed to carry out the water piping work of the unit. Under no circumstances must this work be done by an unqualified individual since failure to carry out the work properly may result in water leakage.

- When a water supply pipe is connected to the system, relevant local ordinances and standards must be followed. The improper pipe connection may cause water leakage, etc. Ask a qualified installer (\*1) or qualified service person (\*1) to carry out the water piping work.

## **Operation**

- Inside the unit are high-voltage areas and rotating parts. Due to the danger of electric shocks or of your fingers or physical objects becoming trapped in the rotating parts, do not remove the service panel of the unit. When work involving the removal of these parts is required, contact a qualified installer or a qualified service person.
- Fix all of the service panels firmly in place. There are component parts with pressurized gas and/or high voltage inside the unit. If the panels are opened by accident, an injury and electric shocks may occur.
- When the unit is operated with a combustion appliance in the same place, be careful of ventilation to let fresh air enter the room. Poor ventilation causes oxygen shortage.
- When the unit is used in a closed room, be careful of sufficient ventilation of the room. Poor ventilation causes oxygen shortage.
- Do not expose your body to exhaust air directly for a long time and do not cool or heat yourself excessively. Doing so may result in deteriorated physical condition and ill health.
- Never insert your finger or a stick into the air discharge. Doing so may result injury as the fan is rotating at high speed inside the unit.
- Consult the shop where you purchased the unit if water temperature control (cooling and heating) is not performed properly as a refrigerant leakage may be the cause. Confirm the repair details with a qualified service person (\*1) when the repair includes additional charging of the refrigerant.
- Be sure to stop running the unit and turn off the circuit breaker before cleaning. Otherwise, a fire, electric shocks, injury may result.
- Do not insert a finger, stick and so on into the fans and pump.

## **Repairs**

- When you have noticed that some kind of error (such as when an error display has appeared, there is a smell of burning, abnormal sounds are heard, the unit fails to cool or heat or water is leaking) has occurred in the unit, do not touch the unit yourself but lock the circuit breaker in the OFF position, place a "out of service" sign near the circuit breaker, and contact a qualified service person. Continuing to use the unit in the error status may cause mechanical problems to escalate or result in electric shocks, etc.
- If you have discovered that the fan grille is damaged, do not approach the unit but set the circuit breaker to the OFF position, lock the circuit breaker in the OFF position, place a "out of service" sign near the circuit breaker, and contact a qualified service person to have the repairs done. Do not set the circuit breaker to the ON position until the repairs are completed.
- If you have discovered that there is a danger of the unit's toppling over, do not approach the unit but set the circuit breaker to the OFF position, lock the circuit breaker in the OFF position, place a "out of service" sign near the circuit breaker, and contact a qualified installer or a qualified service person to have the improvements or refitting done. Do not set the circuit breaker to the ON position until the improvements or refitting is completed.
- Do not customize the unit. Doing so may result in fire, electric shock, etc.
- Ensure sufficient ventilation when making repairs indoors. Refrigerant leakage with poor ventilation may cause an accident such as oxygen shortage.



## **Removal**

- Do not relocate the unit because this unit is one component part installed in the specified fixed equipment as an interpretation of the EMC Directive.
- When the unit is to be removed, do not remove it yourself but contact a qualified installer or a qualified service person. Failure to remove the unit properly may result in a fire, electric shocks, injury, water leakage, and/or refrigerant leakage.
- Be sure to use a refrigerant recovery machine to recover the refrigerant when removing or repairing.
- Only a qualified installer or qualified service person is allowed to remove the unit. It is dangerous for the unit to be removed by an unqualified individual since a fire, electric shocks, injury, water leakage, and/or refrigerant leakage may result.  
(When the unit is to be removed, do not remove it yourself but contact a qualified installer or a qualified service person. Failure to remove the unit properly may result in a fire, electric shocks, injury, water leakage, and/or refrigerant leakage.)

## **CAUTION**

### **To disconnect the appliance from the main supply**

- This appliance must be connected to the mains power supply by means of a circuit breaker with a contact separation of at least 3 mm.

## **New refrigerant**

- This unit adopts the new HFC refrigerant (R32) which does not destroy ozone layer.
- The characteristics of R32 refrigerant are; easy to absorb water, oxidizing membrane or oil, and its pressure is approx. 1.6 times higher than that of refrigerant R22. Accompanied with the new refrigerant, refrigerating oil has also been changed. Therefore, during repair work, be sure that water, dust, former refrigerant, or refrigerating oil does not enter the refrigerating cycle.
- To prevent charging an incorrect refrigerant and refrigerating oil, the sizes of connecting sections of charging port of the main unit and installation tools are changed from those for the conventional refrigerant.
- Accordingly the exclusive tools are required for the new refrigerant (R32).
- For connecting pipes, use new and clean piping designed for R32, and please care so that water or dust does not enter.

## **Installation**

- Certainly lay the drain pipe for perfect draining. Bad drainage may cause flooding around the unit and getting ground wet.
- Make sure to connect the unit to an exclusive power supply of the rated voltage, otherwise the unit may break down or cause a fire.
- After the installation work has been completed, have the installer explain about the circuit breaker positions. In the event that error has occurred in the unit, set the circuit breaker to the OFF position, and contact a service person.

## **Operation**

- Do not use this unit for special purpose such as preserving food, precision instruments, art objects, breeding animals, car, vessel, etc.
- Do not touch any switches with wet finger, otherwise you may get an electric shock.
- If the unit will not be used for a considerably long time, turn off the circuit breaker, for safety. In addition, bleed the pipe of water or fill with antifreeze solution in the pipe to prevent breakage caused by freezing.

- To make the unit operate in its original performance, operate it within the range of the operating temperature specified in the instructions. Otherwise it may cause a malfunction.
- Do not wash the unit. Doing so may result in electric shock.
- Check whether the installation base and other equipment have become deteriorated after being used for a long time. Leaving them such condition may result in the unit's falling down and causing injury.
- Do not leave flammable sprays or other flammable materials near the unit, and do not spray flammable aerosol directly to the unit. They may catch fire.
- Do not put a water container such as a vase on the unit. Water intrusion into the unit may occur and it may cause deterioration of electric insulation and result in electric shock.
- Ask for cleaning of the unit to be performed by the dealer. Cleaning the unit in an improper manner may cause damage to plastic parts, insulation failure of electric parts, etc. and result in a malfunction. In the worst case, it may result in water leakage, electric shock, smoke emission and fire.
- Do not wash units with pressure washers. Electric leaks may cause electric shocks or fires.
- Do not short-circuit the protective devices to operate the unit forcibly and do not change the settings on the protective devices. Doing so may cause a fire or explosion.
- Do not start and stop the unit by turning the circuit breaker ON and OFF. Doing so may cause a fire and electric shocks.
- Do not fill the fusible plug on the refrigerant pipe with solder, etc. Doing so may cause an explosion.
- Do not install the unit in a location in which the exhaust air blows directly on plants and animals. Doing so may adversely affect the plants and animals.
- Do not place objects on the unit. Falling of the objects may cause an injury.
- Do not use any other heat medium except water including water with antifreeze solution. Doing so may cause a fire or explosion.
- Use water that meets the water quality standards. Lower water quality may cause capacity shortage and water leakage.
- Do not drink the water. Doing so may adversely affect your health.

### **Repairs**

- Releasing fluorocarbons into the atmosphere is prohibited. The fluorocarbons in the unit must be recovered when doing repair or removal.
- Dispose of special brine such as antifreeze solution according to legal regulations. Do not connect any special brine drain pipes to water drain pipes.
- Use only fuses with the correct capacity. Use of wires may cause a fire.
- Do not touch the hot parts of the compressors and refrigerant pipes. You may burn yourself if you touch the hot parts.

# List of Equipment • Configuration of Heat Pump

## List of Equipment (standard line-up and capacities)

(common to integrated inverter pump and pumpless)

Item				Unit																
Number of modules				Horse power																
				50	100	150	200	250	300	350	400	450	500	550	600	650	700	750	800	
50HP	Standard type High EER type	Heat pump	Cooling Capacity	kW	150	300	450	600	750	900	1050	1200	1350	1500	1650	1800	1950	2100	2250	2400
			Heating Capacity																	
50HP (powerful heating type)	Standard type High EER type	Heat pump	Cooling Capacity	kW	150	300	450	600	750	900	1050	1200	1350	1500	1650	1800	1950	2100	2250	2400
			Heating Capacity																	

Horse power				Horse power	60	120	180	240	300	360	420	480	540	600	660	720	780	840	900	960
60HP	Standard type High EER type	Heat pump	Cooling Capacity	kW	180	360	540	720	900	1080	1260	1440	1620	1800	1980	2160	2340	2520	2700	2880
			Heating Capacity																	
60HP (powerful heating type)	Standard type High EER type	Heat pump	Cooling Capacity	kW	180	360	540	720	900	1080	1260	1440	1620	1800	1980	2160	2340	2520	2700	2880
			Heating Capacity																	

Horse power				Horse power	70	140	210	280	350	420	490	560	630	700	770	840	910	980	1050	1120
70HP	Standard type High EER type	Heat pump	Cooling Capacity	kW	200	400	600	800	1000	1200	1400	1600	1800	2000	2200	2400	2600	2800	3000	3200
			Heating Capacity																	
70HP	Standard type High EER type	Heat pump	Cooling Capacity	kW	200	400	600	800	1000	1200	1400	1600	1800	2000	2200	2400	2600	2800	3000	3200
			Heating Capacity																	

## Reading a model name

R U A G P 5 1 1 H L Z G 3 T R

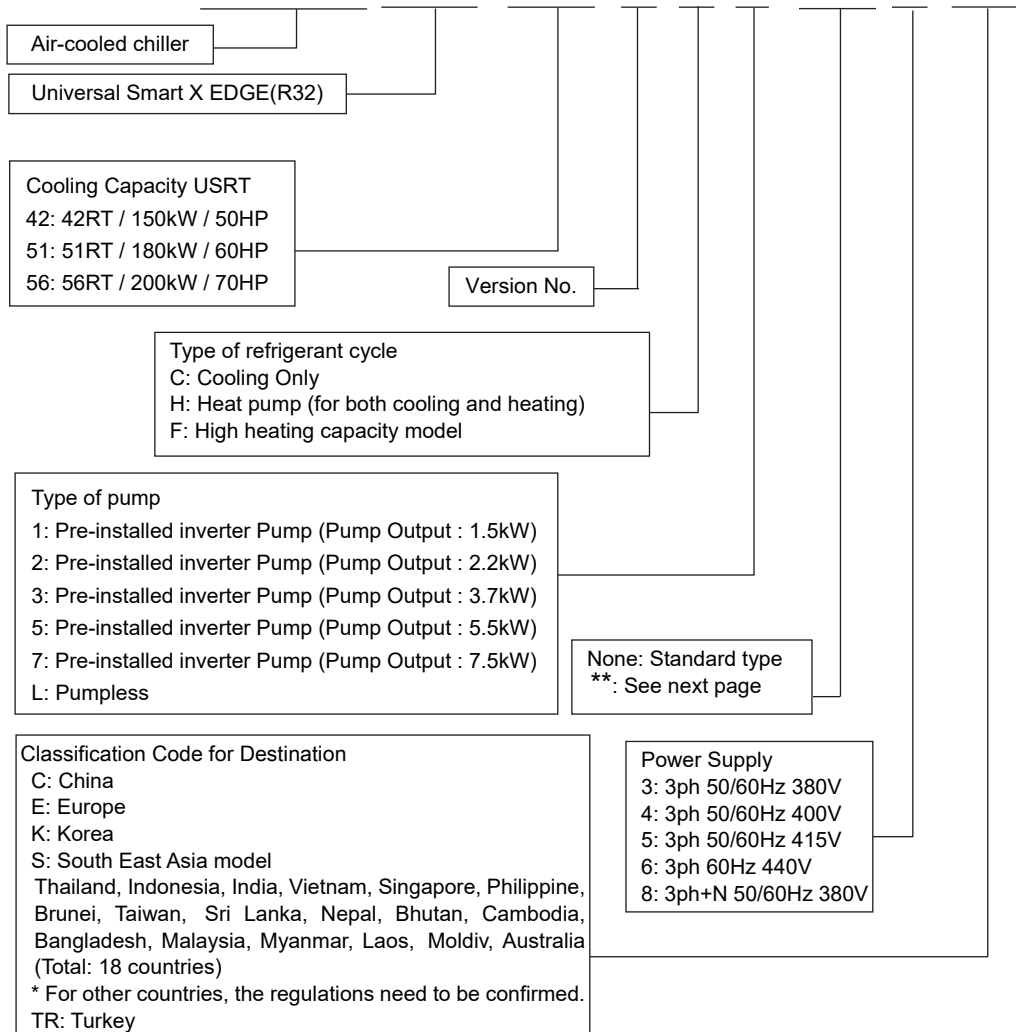

code	High EER type	Brine specifications	Resistance to salt	High resistance to salt
N	●			
R		●		
Z			●	
ZG				●
NR	●	●		
NZ	●		●	
NG	●			●
RZ		●	●	
RG		●		●
WZ	●	●	●	
WG	●	●		●

## Configuration of Heat Pump

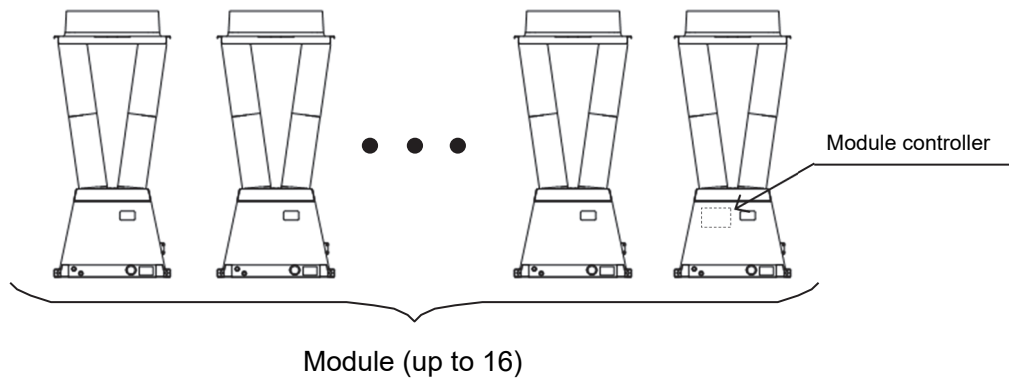

Note) One module controller can control up to 16 modules.

# Dimensional drawings (Integrated inverter pump, pumpless)

## Standard type\_50HP, 60HP

No.	NAME	JOINT
1	WATER INLET	2-1/2" FLANGE
2	WATER OUTLET	2-1/2" FLANGE
3	COIL DRAIN	PT1-1/2" EXTERNAL THREAD
4	AIR VENT VALVE	PT1-1/2" INTERNAL THREAD
5	STRAINER	CASING: Equivalent to FC250
6	CHECK VALVE	CASING: Equivalent to FC200
7	WATER PIPING (INLET)	JIS10K FLANGE Equivalent to SUS304
8	WATER PIPING (OUTLET)	JIS10K FLANGE Equivalent to SUS304
9	PUMP	CASING: FC200
10	WATER HEAT EXCHANGER	PLATE, JOINT Equivalent to SUS316 SOLDER PURE COPPER
11	HOUSING TYPE JOINT	GASKET *1 EPDM

\*1 DESCRIPTION OF WETTED PART

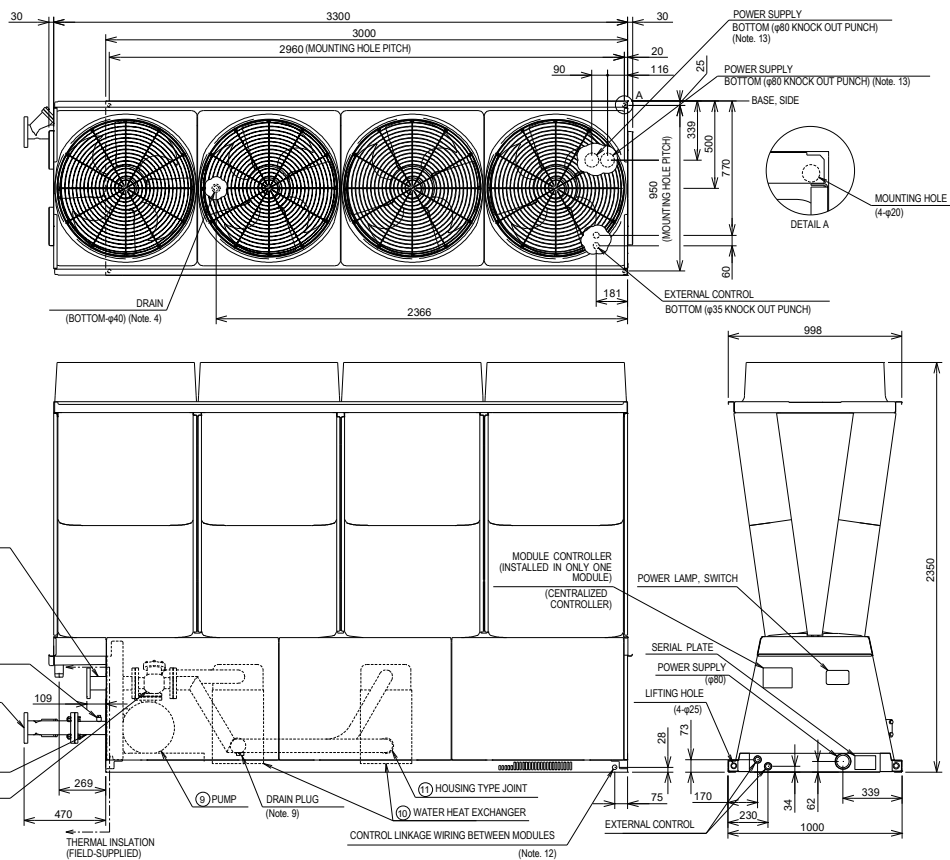

## Standard type\_70HP

No.	NAME	JOINT
1	WATER INLET	3" FLANGE
2	WATER OUTLET	3" FLANGE
3	COIL DRAIN	PT1-1/2" EXTERNAL THREAD
4	AIR VENT VALVE	PT1-1/2" INTERNAL THREAD
5	STRAINER	CASING: Equivalent to FC250
6	CHECK VALVE	CASING: Equivalent to FC200
7	WATER PIPING (INLET)	JIS10K FLANGE Equivalent to SUS304
8	WATER PIPING (OUTLET)	JIS10K FLANGE Equivalent to SUS304
9	PUMP	CASING: FC200
10	WATER HEAT EXCHANGER	PLATE, JOINT Equivalent to SUS316 SOLDER PURE COPPER
11	HOUSING TYPE JOINT	GASKET *1 EPDM

\*1 DESCRIPTION OF WETTED PART

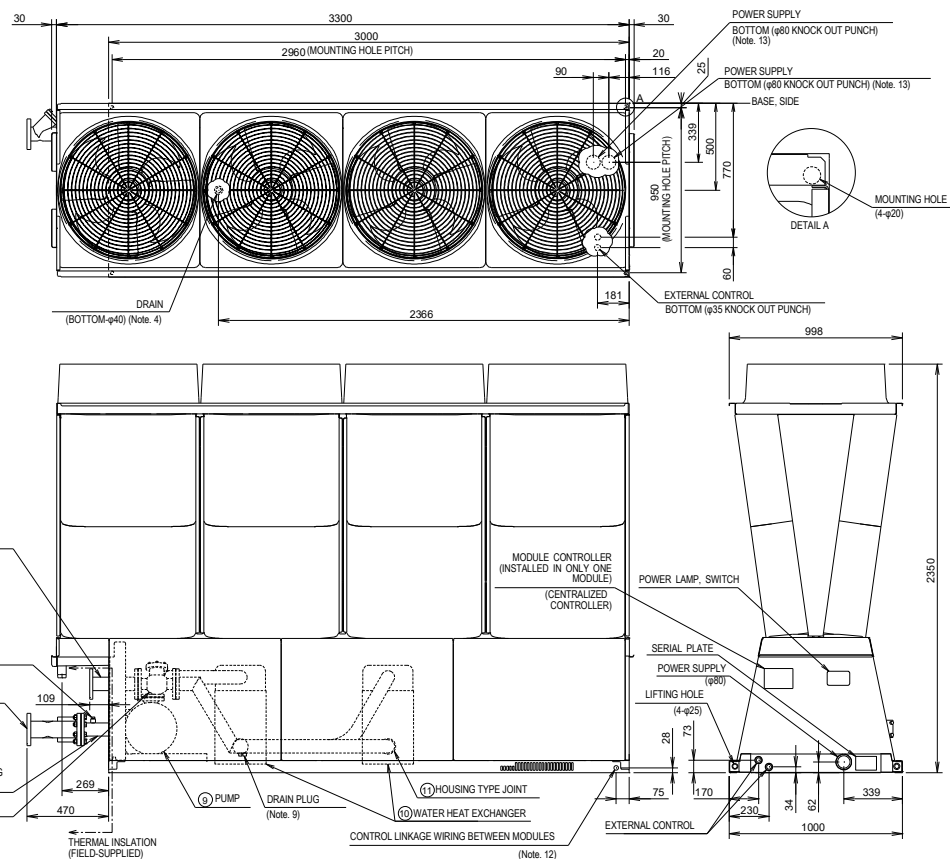

# High EER Type\_50HP, 60HP

No.	NAME	JOINT
1	WATER INLET	2-1/2" FLANGE
2	WATER OUTLET	2-1/2" FLANGE
3	COIL DRAIN	PT1-1/2" EXTERNAL THREAD
4	AIR VENT VALVE	PT1/2" INTERNAL THREAD
5	STRAINER	CASING: Equivalent to FC250
6	CHECK VALVE	CASING: Equivalent to FC200
7	WATER PIPING (INLET)	JIS10K FLANGE PIPING Equivalent to SUS304
8	WATER PIPING (OUTLET)	JIS10K FLANGE PIPING Equivalent to SUS304
9	PUMP	CASING: FC200
10	WATER HEAT EXCHANGER	PLATE JOINT SOLDER Equivalent to SUS316 PURE COPPER
11	HOUSING TYPE JOINT	GASKET *1 EPDM
12	WATER SUPPLY PORT FOR SPRAY	PT1/2" EXTERNAL THREAD

\*1 DESCRIPTION OF WETTED PART

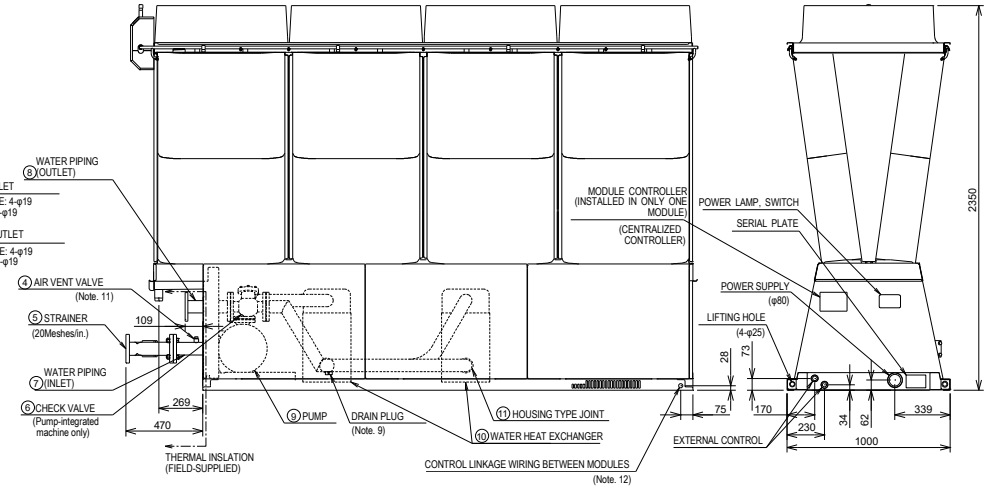
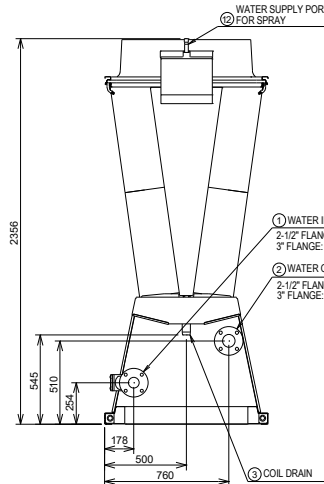
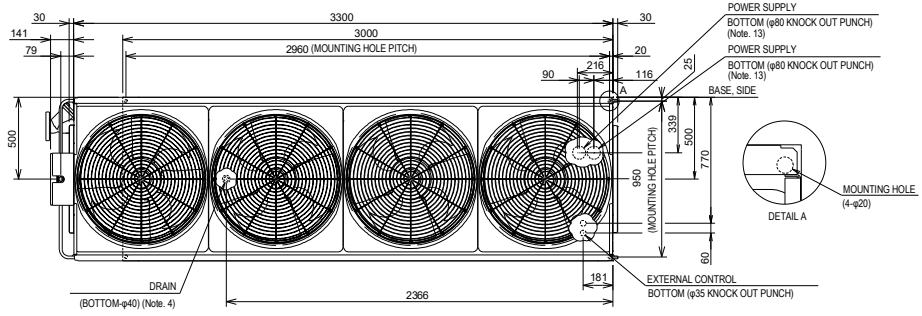

# High EER Type\_70HP

No.	NAME	JOINT
1	WATER INLET	3" FLANGE
2	WATER OUTLET	3" FLANGE
3	COIL DRAIN	PT1-1/2" EXTERNAL THREAD
4	AIR VENT VALVE	PT1/2" INTERNAL THREAD
5	STRAINER	CASING: Equivalent to FC250
6	CHECK VALVE	CASING: Equivalent to FC200
7	WATER PIPING (INLET)	JIS10K FLANGE PIPING Equivalent to SUS304
8	WATER PIPING (OUTLET)	JIS10K FLANGE PIPING Equivalent to SUS304
9	PUMP	CASING: FC200
10	WATER HEAT EXCHANGER	PLATE JOINT SOLDER Equivalent to SUS316 PURE COPPER
11	HOUSING TYPE JOINT	GASKET *1 EPDM
12	WATER SUPPLY PORT FOR SPRAY	PT1/2" EXTERNAL THREAD

\*1 DESCRIPTION OF WETTED PART

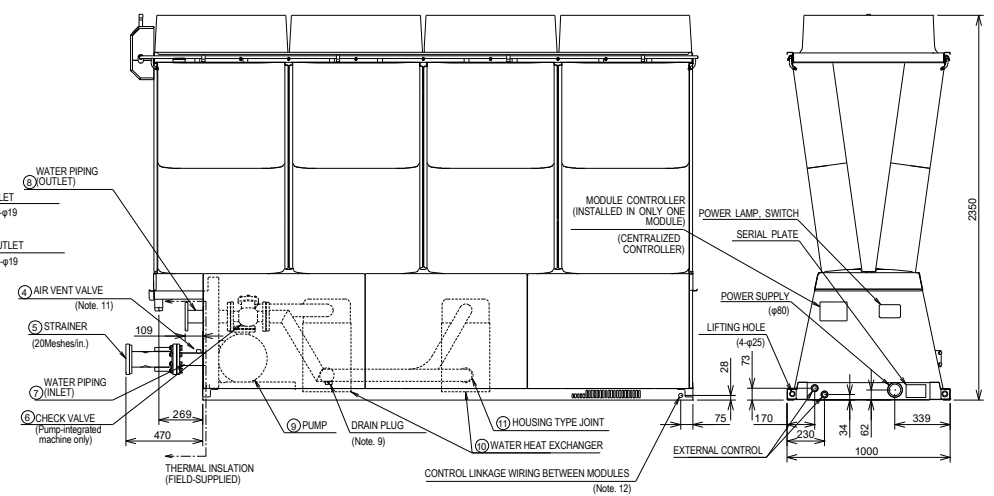
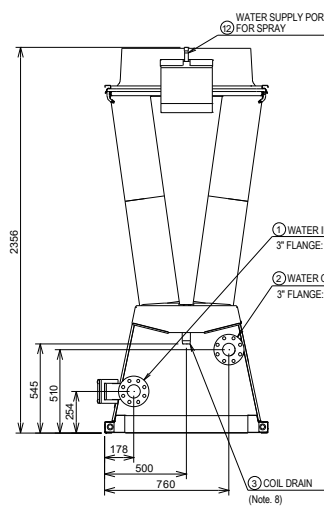
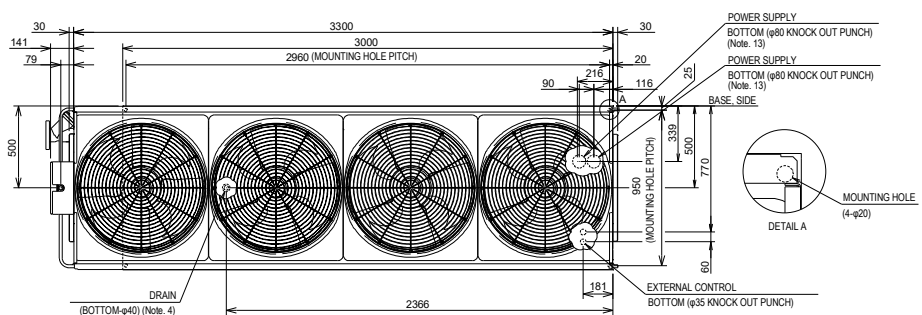

# ● Installed in a connected state

Note 2.number for A, B, C in the drawing.

Number of Modules	A	B	C
1	1000	1	4
2	2030	2	8
3	3060	3	12
4	4090	4	16
5	5120	5	20
6	6150	6	24
7	7180	7	28
8	8210	8	32
9	9240	9	36
10	10270	10	40
11	11300	11	44
12	12330	12	48
13	13360	13	52
14	14390	14	56
15	15420	15	60
16	16450	16	64

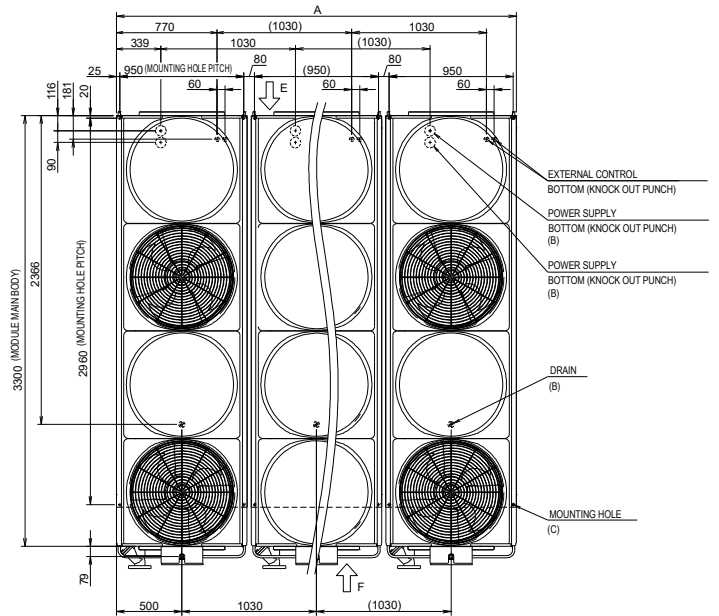
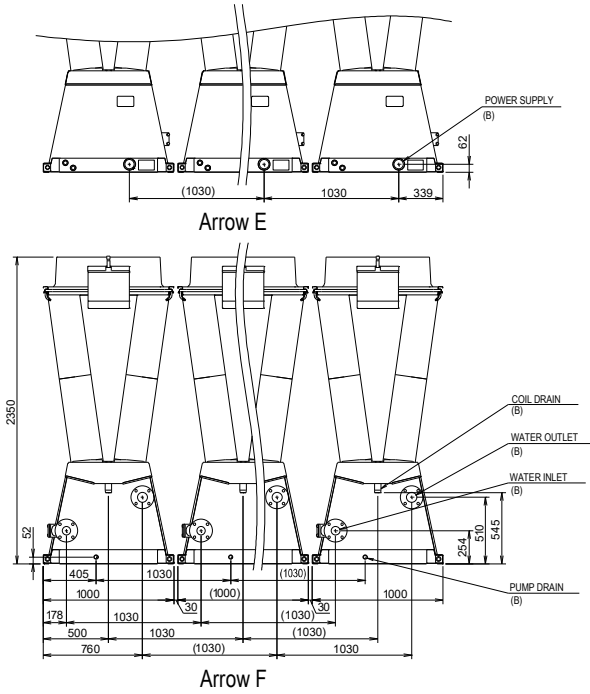

# Control box layout diagram

## Control box layout

The layout of the control boxes in the module is as shown below.

The power supply control box contains a power supply switch, module controller (\*typical model only), unit controller and CPU control board.

Each of the inverter boxes contains two compressor (PWM) control boards. Each of the EEV boxes contains one EEV board.

Note 1) Pump inverter box is limited to integrated inverter pump only.

Note 2) The heater box is limited to 50HP, 60HP (Powerful heating type) only.

Note 3) The relative humidity sensor box is limited to 50HP, 60HP (Powerful heating type) including MC only.

## BOX Layout Diagram

(Water spray system is omitted)

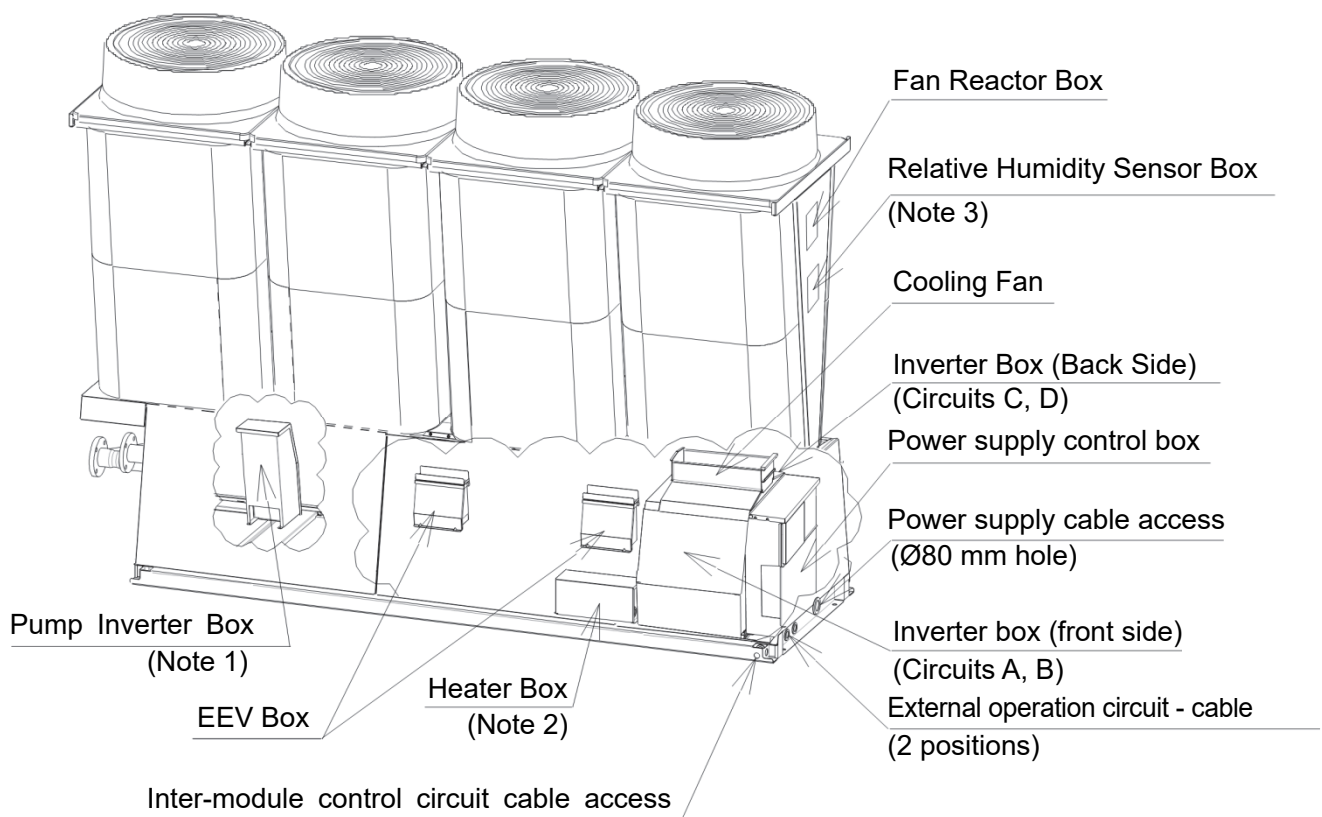



# High EER Type Drainage

During the winter, water inside the sprinkler can freeze, creating the risk of spray damage. If the outdoor air temperature becomes 0°C or less, use one of the following two methods to drain water from the sprinkler.

**[Drain all at once from module controller]** \* Group must be stopped

- (1) Set the operation of the heat pump to Stop.

To stop using the module controller, switch to "Stop" in the MC operation change screen.

- (2) Set the module controller to Unit.

In the Remote change screen of the module controller, switch to "Unit".

Module controller screen

Main					18-03-19(Mon)13:54	
Stop	Unit	MC pattern 1			Remote change	
Sys	UC No.	Mode	State	PST	PST	
MC-A	2	Cool	Stop	7.0	Demand	
EWT	LWT	D.C	Demand	Fail	UC operate	
-88.8	-88.8	0	OFF			
Sys	UC No.	Mode	State	PST		
---	---	---	---	---		
EWT	LWT	D.C	Demand	Fail		
---	---	---	---	---		

(1) Stop

(2) Unit

- (3) Close the gate valves of the water supply main pipe for the spray and stop water supply to each module.

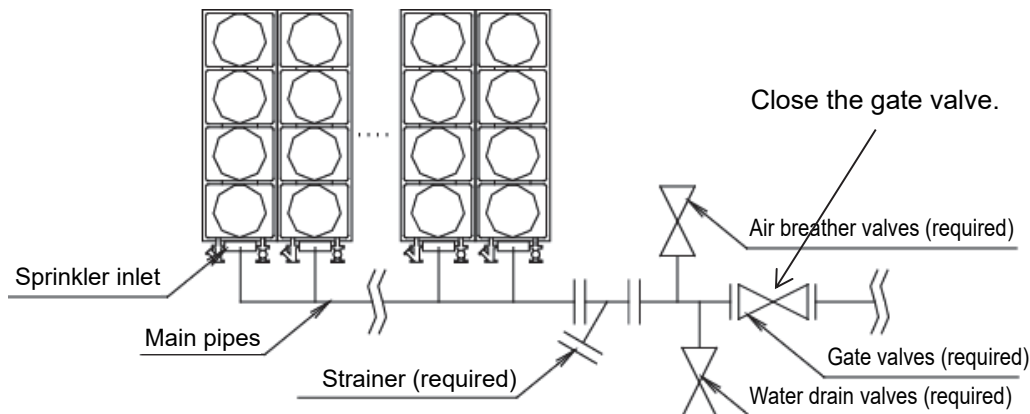

- (4) Fully open the manual flow rate adjustment valve of the sprinkler inlet.

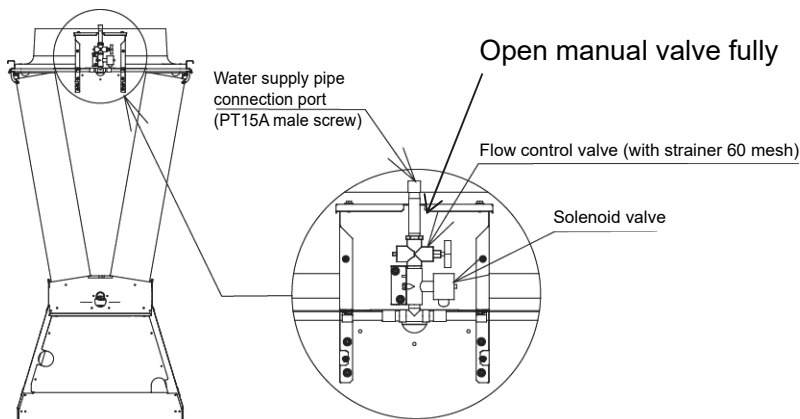

(5) Set the solenoid valve for the spray to ON (open).

From the operation screen, select "Main screen → Service →MC func →MC mainte →Fan and Spray check", and set the spray of "System A (or B)" to ON.

(6) When water of all modules are completely drained, set the solenoid valve for the spray to OFF (close).

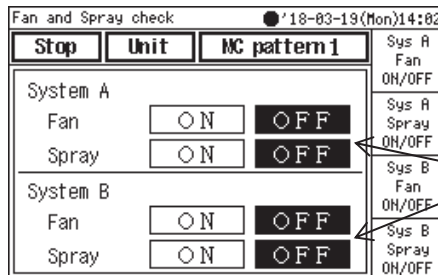

(5) Set to ON (open).  
(6) Set to OFF (close).

#### Cautions

This method can only drain water from the spray inside each module. As shown in "Pipe example", water drain valves (procured locally) also need to be provided in the collecting pipe to each module. Be sure to use these valves to drain water.

**[When draining separately with unit controller of each module] \*Stopping by each module is possible**

- (1) Touch REMOTE in the power control box of the module to drain, set it to Unit (REMOTE lamp off), and touch STOP to stop the module.

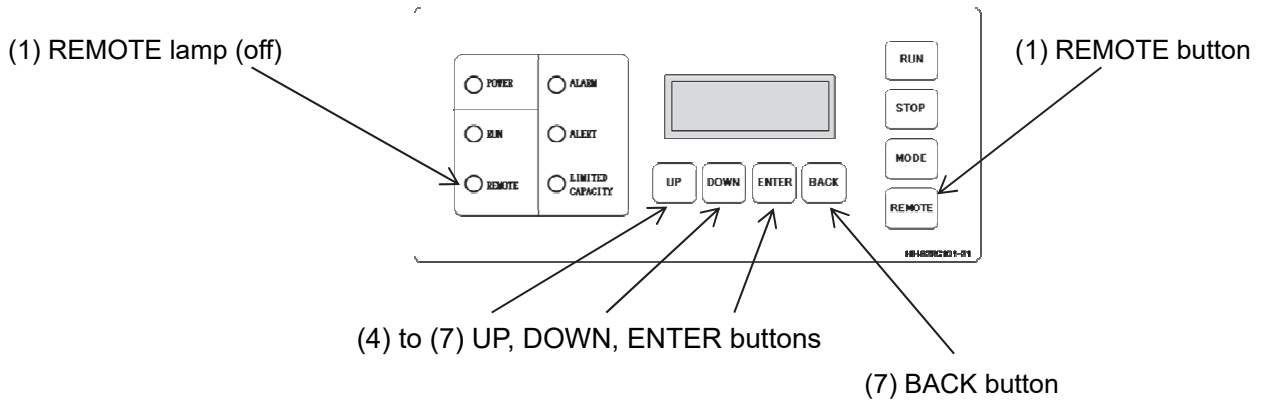

- (2) Close the gate valves of the main pipe and stop water supply to the module.
- (3) Fully open the manual flow rate adjustment valve of the spray inlet.
- (4) Use UP or DOWN of the unit controller to select "E.CoDE", and touch ENTER.
- (5) Use UP or DOWN to select SPry, and touch ENTER to enter the manual mode of the solenoid valve for the spray.



- (6) Use UP or DOWN to select On (open), and touch ENTER.

\* In the manual mode, use UP or DOWN to select Ctrl (automatic), On (open), or OFF (close), and touch ENTER to confirm.



- (7) When water is completely drained, select Ctrl (automatic) and touch ENTER. Then touch BACK to exit the manual mode.
- (8) Perform the same procedure to drain water from the other modules.

**Cautions**

This method can only drain water from the spray inside each module. As shown in "Pipe example", water drain valves (procured locally) also need to be provided in the collecting pipe to each module. Be sure to use these valves to drain water.

# Module Controller

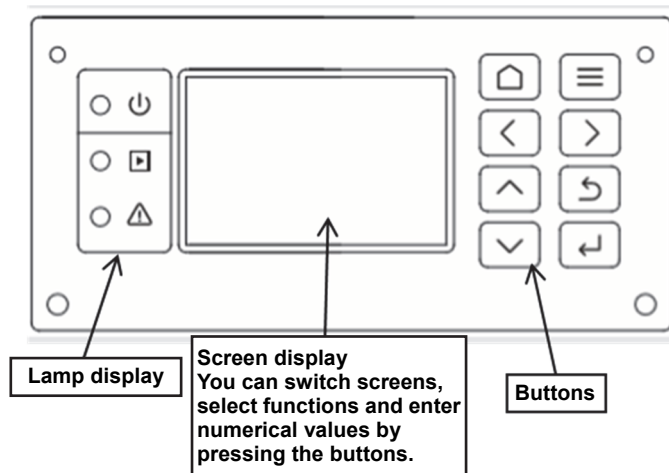

## Lamp display

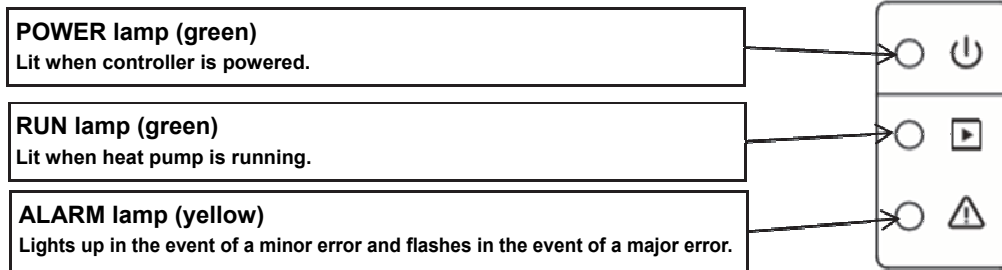

## Button layout and name

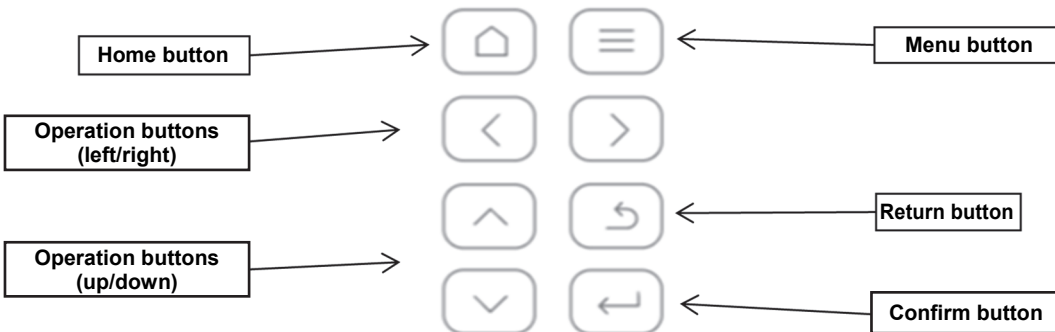

Button name	Display	Description
Home button		• Returns to the home screen.
Menu button		• Displays the menu list.
Cursor operation button		• Moves the cursor and applies various settings.
Return button		• Returns to the previous screen. • Displays a message to confirm the setting change.
Confirm button		• Applies various settings. • Move on to the next screen.

# Screen configuration

## ① Transition from Home screen

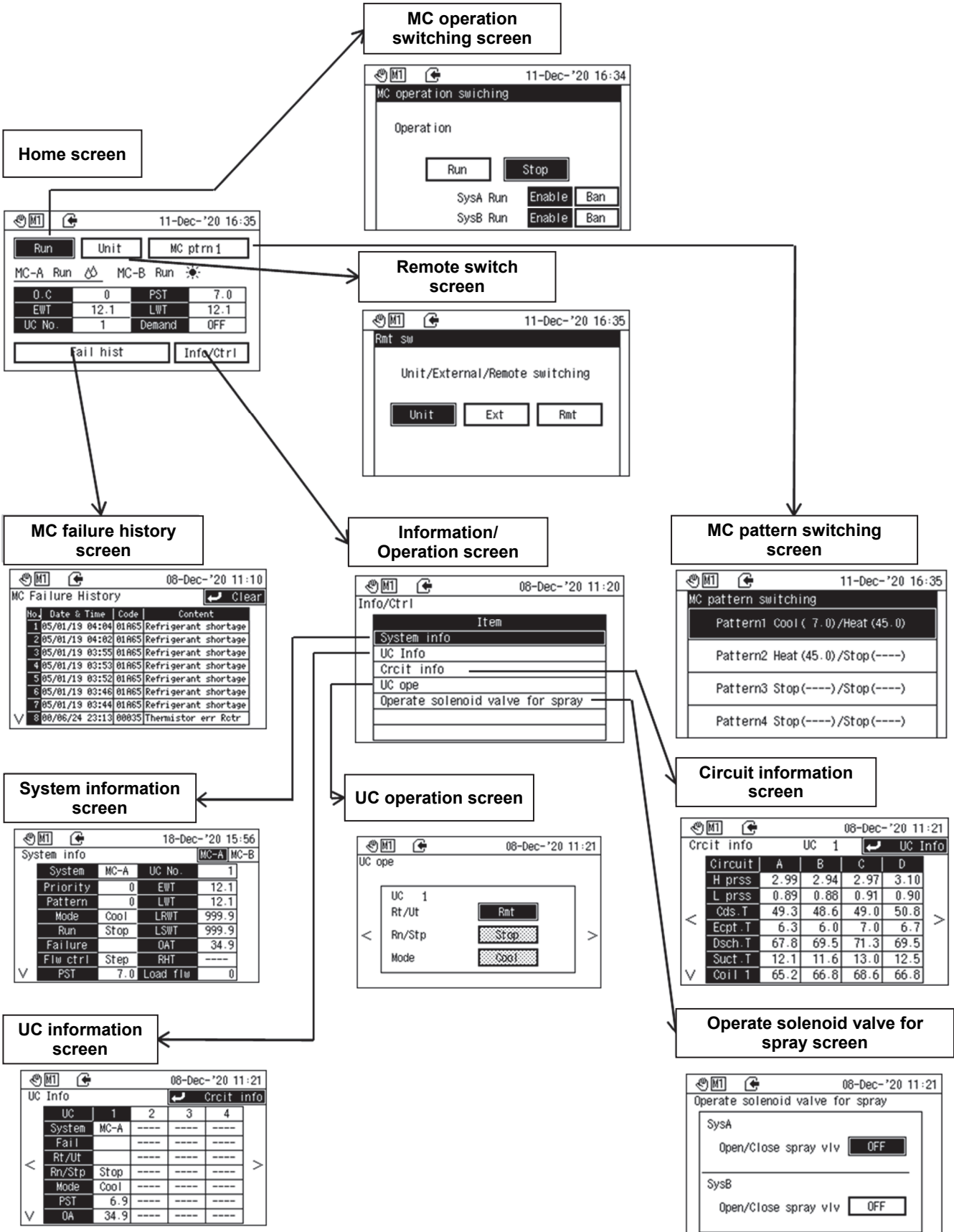

② Transition from menu button

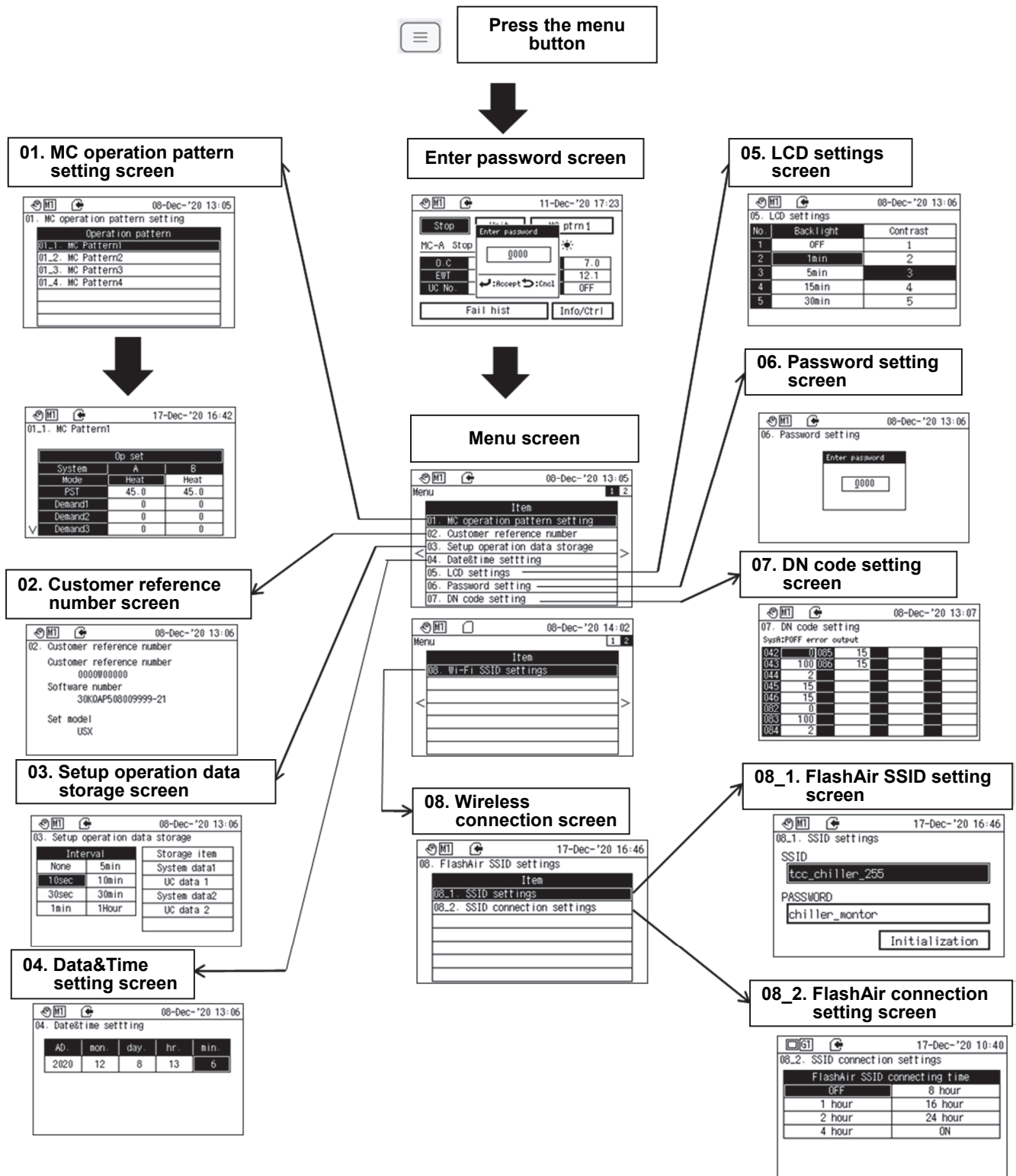

Bar at the top of the screen

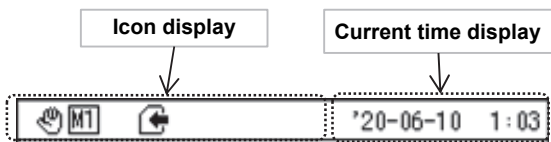

[About icon display]

For the meaning of each icon, refer to the table below.

Classification	Display	Name	Description
Operation mode		Unit	Button operation
		Remote	Operation from GC or Modbus control
		External	External I/O
Pattern		MC pattern 1	Button, external or specified pattern from Modbus
		MC pattern 2	
		MC pattern 3	
		MC pattern 4	
	Specified pattern from GC		GC pattern 1
			GC pattern 2
			GC pattern 3
			GC pattern 4
			GC pattern 5
			GC pattern 6
			GC pattern 7
			GC pattern 8
Demand	Hidden	No demand	
		Demand	Demand limit ON/OFF
SD operation		Saving	Saving data
		Waiting to save	No settings saved while SD is inserted
		Other error	Other error
	Hidden	None	SD not inserted
Wireless		Connecting	
	Hidden	No connection	
Failure		Failure state	
	Hidden	No failure	

Button display

Display types that can be selected with the cursor

Button not selected (with setting)	White letters on black background	
Button not selected (no setting)	Black letters on white background	
Button selected	White letters in white frame on black background	
Button operation disabled	Shaded state	



### Screen switching operation

[To move to a lower level screen]

- Move the cursor to position and press  to switch the screen to the next level.





[When confirming on the "MC operation switching" screen, "Remote switching" screen, "MC pattern switching" screen, "Solenoid valve for spray operation" screen]

- Press  to confirm the changes and return to the previous screen.

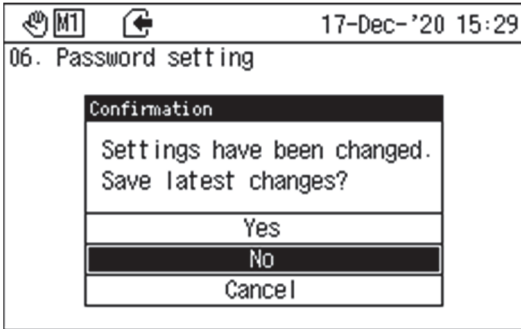
[When confirming on the message screen]







- Press  to display the confirmation screen.

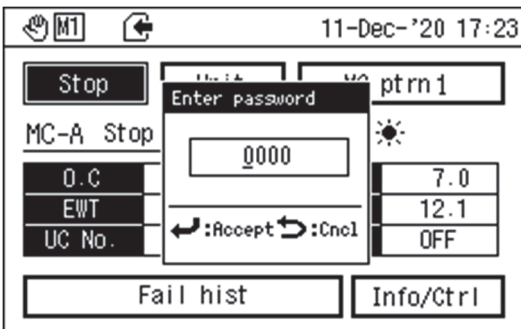

- Select "Yes" and press  to confirm the changes and return to the previous screen.
- Select "No" and press  to discard the changes and return to the previous screen.
- Select "Cancel" and press  to discard the changes and return to the original screen.
- \* If you make a change, even if the setting is the same as before the change, press  to display the confirmation screen.

### Value input screen



- To enter numerical values, perform the following operations.
- Press  or  to select the digit to be changed.
- Press  or  to change the value.
- Press  to reflect the entered value.
- Press  to cancel the entered value and return to the previous screen.



Home screen

[About the display]

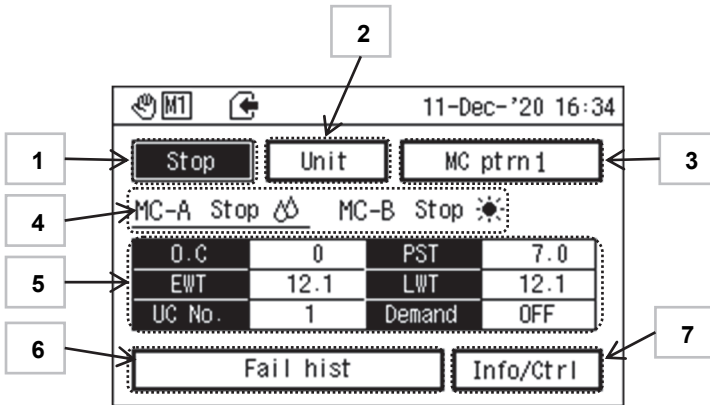

- 1, 2, 3, 6, 7 in the figure below are buttons. Select with the cursor and press . See the table below for the destination.



Refer to the table below for the display of 1 to 7.

	Classification	Display	Description	Destination
1	Operating status	Run	Operating	MC operation switching screen
		Stop	Operation stopped	
2	Operation mode	Unit	Unit selected (control by button operation)	Remote switching screen
		Remote	Remote selected (controlled by GC)	
		External	External selected (controlled by Modbus)	
3	Pattern	MC pattern 1	MC pattern 1 selected	MC pattern * Display only during GC operation
		MC pattern 2	MC pattern 2 selected	
		MC pattern 3	MC pattern 3 selected	
		MC pattern 4	MC pattern 4 selected	
		GC pattern 1	GC pattern 1 selected	
		GC pattern 2	GC pattern 2 selected	
		GC pattern 3	GC pattern 3 selected	
		GC pattern 4	GC pattern 4 selected	
		GC pattern 5	GC pattern 5 selected	
		GC pattern 6	GC pattern 6 selected	
		GC pattern 7	GC pattern 7 selected	
		GC pattern 8	GC pattern 8 selected	
4	System status	System name	Displays "MC-A" or "MC-B"	Display only * Switching system data
		Run	Operating	
		Stop	Operation stopped	
		Disable	Disabled operation selected	
		Cooling symbol	Cooling mode selected	
		Heating symbol	Heating mode selected	
		Stopped symbol	Stopped is selected in the operation pattern settings	
5	System status data	Ope Capa	Operating capacity of compressor	Display only
		Setting	Set outlet water temperature	
		EWT	Inlet water temperature	
		LWT	Outlet water temperature	
		UC No.	Number of connected UCs	
		Demand	Set value when demand control is enabled, OFF when disabled	
6	Failure display	Fail hist	Displays failure code during failure reporting	Failure log

\*1 Details of the cooling, heating, and stopping icons are as described below.

Display	Name	Description
	Cooling symbol	In cooling operation
	Heating symbol	In heating operation
	Stopped symbol	Operation stopped

MC operation switching screen

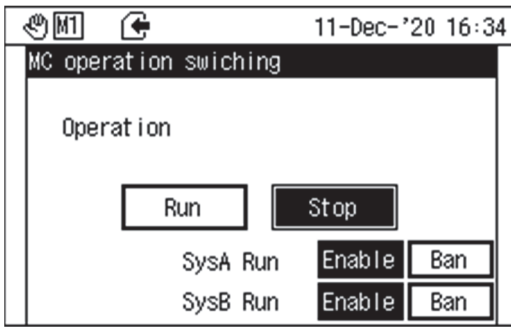

- Use the cursor to select "Run" or "Stop" of "MC Operation". Also, select either "Enable" or "Disable" for "System A operation" and "System B operation". If "Disable" is selected, the corresponding system will not operate even if "MC operation" is set to "Run".
- If "Run" is applied, the "Run" lamp lights up. The pump starts up first, followed by restart of the compressor and other devices. If "Stop" is applied, the compressor and other devices stop, and the "Run" lamp turns off. (Subsequently, the pump continues running for at least 15 seconds.)
- When the operation setting is "Unit", operation enable/disable for each MC operation system can be operated. The functions that can be operated will change depending on the settings for "External" and "Remote".

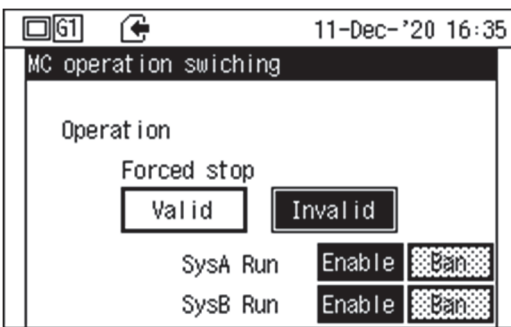

- You cannot start the MC but can force it off 1) when the External mode is selected and the "Run/Stop" input is specified in the I/O Settings or 2) when the Remote mode is selected. When forced stop (Unit stop) "Enable" is selected during "External" or "Remote" operation, the operation is automatically switched to local operation and operation is stopped.

Remote switch screen

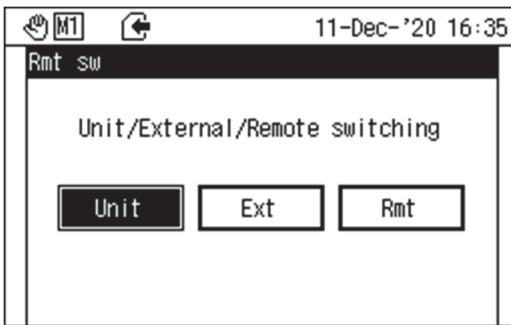

- Use the cursor to select "Unit", "External" or "Remote switching" from "Unit/Ext/Rmt". Refer to the table below for the items and content of display information.

Item	Description
Unit	Operate with the MC (module controller) button.
External	Operation is controlled by the external I/O signal.
Remote	Operation is controlled by the GC (group controller) or Modbus.

MC pattern switching screen

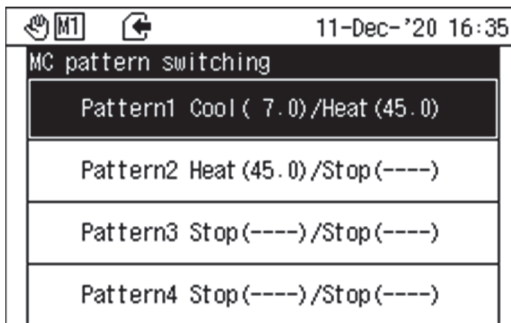

- Use the cursor to select from "MC patterns 1 to 4" of "MC pattern switching".
  - The operation is controlled according to the setting content of the selected "MC pattern".
  - MC pattern switching is enabled when the operation settings are "Unit" or "External" and the pattern input is not set in the I/O settings.
  - You can change the operation pattern while the heat pump is running. However, if the system setting or operating mode changes, the operation stops once. \*1 (For the target system)
- \*1 Continued operation is also possible depending on the settings.  
 \*2 The setting content of each MC pattern can be set in "01\_Unit/External operation setting" screen.

MC Failure history screen

No.	Date & Time	Code	Content
1	05/01/19 04:04	01A65	Refrigerant shortage
2	05/01/19 04:02	01A65	Refrigerant shortage
3	05/01/19 03:55	01A65	Refrigerant shortage
4	05/01/19 03:53	01A65	Refrigerant shortage
5	05/01/19 03:52	01A65	Refrigerant shortage
6	05/01/19 03:46	01A65	Refrigerant shortage
7	05/01/19 03:44	01A65	Refrigerant shortage
8	00/06/24 23:13	00035	Thermistor err Rctr

Date and Time	Indicates the date and time of occurrence. (The year is the last 2 digits of the Western calendar year)
Code	Displays a 5-digit code. The left 2 digits indicate the UC number and the right 3 digits indicate the failure code.
Content	Displays the failure content. (Up to 16 latest items can be displayed.)

\* Refer to the list of failure codes for details of the failure codes and their content.

[How to clear failure history]

- Press to display the confirmation screen.
- Refer to "When confirming on the message screen" when using the confirmation screen.

Information/Operation screen

- Use the cursor to select an item.
- Refer to the table below for the items and content of display information.





Item	Description
System info	You can check the operation data for each system.
UC info	You can check the operation data for each UC.
Crcit info	You can check the operation data for each circuit in each UC.
UC ope	You can operate each system of each UC.
Operate solenoid valve for spray	You can turn ON/OFF the solenoid valve for evaporative condenser for each system.

Table - MC error codes

Error codes (Hexadecimal)	Item	Description	UC display	Circuit display	Process
02	Pump interlock	No pump interlock input during operation	0	0	Relevant system stops
1A	HumanIF comm error	Module controller's Human IF communication error	0	0	Operation continues
1C	GC communication err	Communication error (in Remote mode) between module controller and group controller	0	0	Operation continues
1D	MC communication err	Communication error between module controllers (in Remote mode)	0	0	Operation continues with backup (steps) control
E0	Load side RWT error	In case of thermistor sensor Sensor disconnection, short circuit	0	0	When flow meter exists and is normal: Operation continue
E1	Load side SWT error	In case of voltage input In case of voltage judged to be error in analogue input voltage range setting	0	0	When flow meter does not exist or is not normal: Operation continue with backup control
E2	Load side Flow meter	In case of voltage judged to be error in analogue input range setting	0	0	When return water and supply water sensors exist and are normal: Operation continues When return water and supply water sensors do not exist and are not normal: Backup operation
E3	Ext diff prss sensor		0	0	Backup operation

## System information screen

System info			
System	MC-A	UC No.	1
Priority	0	EWT	12.1
Pattern	0	LWT	12.1
Mode	Cool	LRWT	999.9
Run	Stop	LSWT	999.9
Failure		OAT	34.9
Flw ctrl	Step	RHT	----
PST	7.0	Load flw	0

- Use the  and  buttons to switch the displayed system.
- Use the  and  buttons to switch the displayed information item.

Refer to the table below for the items and content of display information.

Item	Unit	Description
System	—	Displays "MC-A" or "MC-B"
UC No.	units	Indicates the number of UCs connected to the system
Mode	—	"Cooling", "Heating" or "Stopped"
Run	—	Displays "Run", "Stopped" or "Disabled"
Failure	—	Failure code is displayed: Failure state Blank: Normal state
Flw ctrl	—	Step (stepped variable flow rate) Byps0 (bypass flow zero control)
PST	°C	Displays the setting outlet water temperature
EWT	°C	Displays the average inlet water temperature of each heat pump
LWT	°C	Indicates the average outlet water temperature of each heat pump
LRWT	°C	Indicates the return water temperature (external input)
LSWT	°C	Indicates the supply water temperature (external input)
OAT	°C	Indicates the average outdoor air temperature of each heat pump
RHT	%	Indicates relative humidity (only for HEATEDGE) For other than HEATEDGE, "----" is displayed
Load flw	L/min	Indicates the flow rate on the load side from the bypass (external input)
Unit flw	L/min	Indicates the total flow rate (external input) of each heat pump
Ope Capa	%	Indicates the average operating capacity of each heat pump
Capacity	kW	Indicates the total capacity of each heat pump
Diff	kPa	Indicates the supply and return water differential pressure (external input)
Vlv opn	%	Indicates the motorized valve opening instruction (external output) installed on the bypass pipe between the supply and return water
Demand	A/kW/%	Displays the demand setting value when demand control is enabled (*) OFF: Demand control disabled
GC	—	Displays GC "System 1 to 16" for remote except for Modbus control

\* The standards that can be set during demand control are "Current (A)", "Operation Capacity (%)", "Rated power ratio (%)", "Power consumption ratio (%)", and "Power (kW)".

## UC information screen

UC	1	2	3	4
System	MC-A	----	----	----
Fail		----	----	----
Rt/Ut		----	----	----
Rn/Stp	Stop	----	----	----
Mode	Cool	----	----	----
PST	6.9	----	----	----
OA	34.9	----	----	----

- Use the and buttons to switch the UC ("1 to 4", "5 to 8", "9 to 12", or "13 to 16") displayed.
- Use the and buttons to switch the displayed information item.

Refer to the table below for the items and content of display information.

Item	Unit	Description
System	—	Displays "MC-A" or "MC-B" (Displays GC "System 1 to 16" for remote except for Modbus control)
Fail	—	Failure code is displayed: Failure state Blank: Normal state
Rt/Ut	—	Displays "Remote" or "Unit"
Rn/Stp	—	Displays "Run" or "Stop"
Mode	—	Displays "Cool" or "Heat"
PST	—	Displays the setting outlet water temperature
OA	°C	Indicates the outdoor air temperature
Room Humidity	%	Indicates relative humidity (only for HEATEDGE with MC) Otherwise "----" is displayed
EWT	°C	Indicates the inlet water temperature
MWT	°C	Indicates the centre water temperature
LWT	°C	Indicates the outlet water temperature
Ope CAPA	%	Displays the operating capacity from 0 to 100%
Demand	A/kW/%	Displays the demand setting value when demand control is enabled (*) OFF: Demand control disabled
PUMP	—	ON: Pump operation OFF: Pump stopped
Flow rate	L/min	Displays the flow rate
EWP	kPa	Indicates entering water pressure
LWP	kPa	Indicates leaving water pressure
PEWP	kPa	Indicates entering water pressure of the pump
UCPD	kPa	Indicates pressure differential between the entering water pressure of the pump and the leaving water pressure of the water heat exchanger
Time	h	Indicates average run hours of the compressors (4 units)
Count	Times	Indicates the average startup count for the compressors (4 units)
GC	—	Displays GC "System 1 to 16" for remote, except for Modbus control

\* The standards that can be set during demand control are "Current (A)", "Operation Capacity (%)", "Rated power ratio (%)", "Power consumption ratio (%)", and "Power (kW)".

### Circuit information screen

Circuit	A	B	C	D
H prss	2.99	2.94	2.97	3.10
L prss	0.89	0.88	0.91	0.90
Cds. T	49.3	48.6	49.0	50.8
Ecpt. T	6.3	6.0	7.0	6.7
Dsch. T	67.8	69.5	71.3	69.5
Suct. T	12.1	11.6	13.0	12.5
Coil 1	65.2	66.8	68.6	66.8

- Use the and buttons to switch the UC ("1 to 16") displayed.
- Each time you press , you can switch the displayed circuit (A→B→C→D). Use the and buttons to switch the displayed information item.

Refer to the table below for the items and content of display information.

Item	Unit	Description
UC	—	Indicates the selected UC number
Circuit	—	Indicates circuit
EWT	°C	Indicates the inlet water temperature
MWT	°C	Indicates the centre water temperature
LWT	°C	Indicates the outlet water temperature
H press	MPa	Indicates the high pressure
L press	MPa	Indicates the low pressure
Cds. T	°C	Indicates the condensing temperature
Ecpt. T	°C	Indicates the evaporation temperature
Dsch. T	°C	Indicates the discharge gas temperature
Suct. T	°C	Indicates the suction gas temperature
Coil 1	°C	Indicates the pipe temperature of the air heat exchanger (heat pump only) When viewed from the controller side, the left side is 1 and the right side is 2 Displays "---" when a cooling-only unit is not installed
Coil 2	°C	
LQT	°C	"---" display
COMP	—	ON: Compressor operation OFF: Compressor stopped
FAN	rpm	Displays the fan rotation speed
Time	h	Displays the operation hours
Count	Times	Displays the number of startups

### UC operation screen

UC 1	
Rt/Ut	
Rn/Stp	
Mode	

- Use the and buttons to switch the UC ("1 to 16") displayed. You can only switch between "Run/Stop" and "Mode" in the case of "Unit".
- Press or to select the item you want to change then press . The confirmation screen appears. To change it with the cursor, select "OK" and press to change. If you do not wish to make a change, select "BACK" and press to return to the "UC operation" screen without making a change.

Refer to the table below for the items and content of display information.

Item	Description
Remote/Unit	"Remote" or "Unit"
Run/Stop	"Run" or "Stop"
Mode	"Cool" or "Heat"

### Operate solenoid valve for spray screen

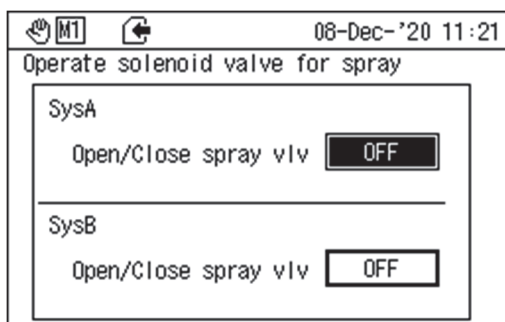

- You can select system A or system B with and .
- Press to switch between "OFF" and "ON".
- If you do not wish to make a change, select and press to return to the "Information/Operation" screen without making a change.

### Enter password screen



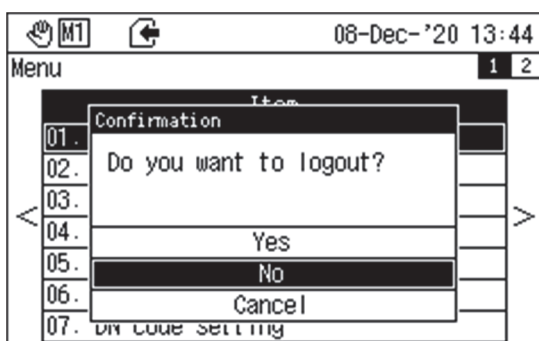

- Press . The password input screen appears.
- Enter four digits for the password from 0000 to 9999.
- \* You can change the password on "06\_Password setting" screen.
- Refer to the "Value input" screen for detailed information about entering a password.
- Press to move to the "Basic settings" screen.
- After entering the password, you will remain logged in for 30 minutes of inactivity. You will not be required to enter your password to display the Menu screen from the Home screen.
- 30 minutes after you enter the password, the device will automatically return to the Home screen and log out.

### Logout message screen



- When you press to return to Home from various setting screens, if you are logged in, a logout confirmation message appears.
- Refer to "When confirming on the message screen" when operating the confirmation screen.

### Basic settings screen

- Press  and enter the password on the password input screen. The following screen appears. If the password is incorrect, the password error screen appears. If you press , the functions will be restricted. If the password is correct, the Basic settings screen that allows selection of 8 items appears.



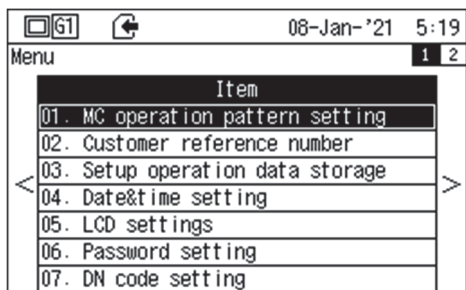

If the password is correct

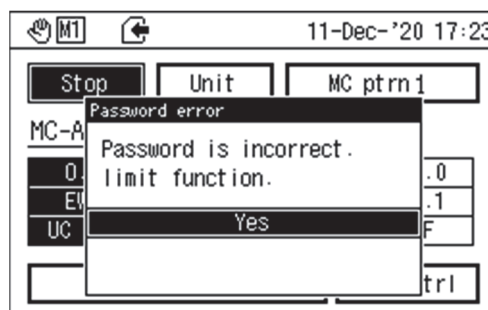

If the password is incorrect



Password error screen

- Press  or  to switch pages.
- You can change the item with  and . Press  to move to each screen.



## 01. MC operation pattern setting screen

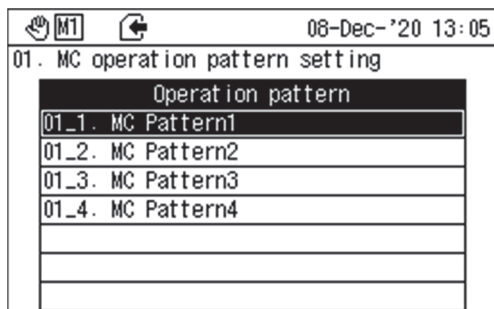

- Select "01. MC operation pattern setting" from . The screen on the left appears.
- You can change the item with and .

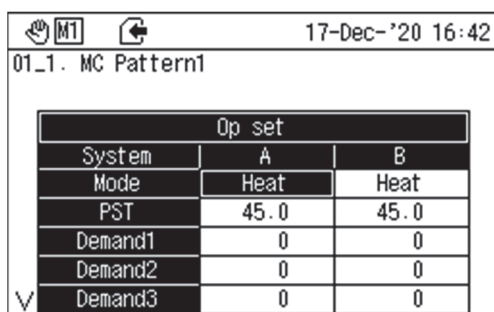

- Select pattern 1 and press to move to the screen on the left (01\_1. MC pattern1 screen). (The same applies to other patterns.)
- You can switch the system with and .
- You can change the item with and .
- The mode changes each time you press .  
(Cool → Heat → CA → HA → Stop)

\* "CA" and "HA" storage are stom options.

- For the set temperature, demand 1, demand 2, and demand 3, press to display the input screen. Refer to the "Value input" screen for detailed information about entering a value.
- The standards that can be set during demand control are "Current (A)", "Operation Capacity (%)", "Rated power ratio (%)", "Power consumption ratio (%)", and "Power (kW)". The demand input title follows the set standard.

Refer to the table below for the items and content of display information.

Item	Setting
Mode	Cooling, Heating, Cool storage, Warm storage, Stop
PST	Cooling: 4. 0 to 30. 0 Heating: 25. 0 to 55. 0
Demand 1	0 to 5000
Demand 2	0 to 5000
Demand 3	0 to 5000
Flw ctrl	step, byps0
Setting	1, 2

\* "Flw ctrl" control and "Setting" are display only.

## 02. Customer reference number

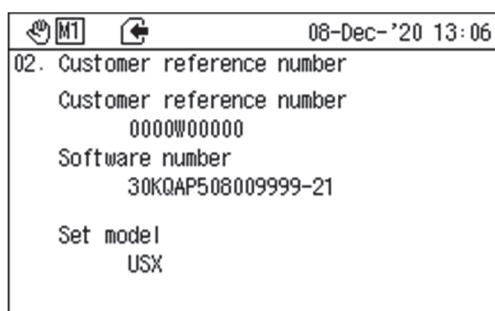

- Select "02. Customer reference number" from . The screen on the left appears.

### 03. Setup operation data storage screen

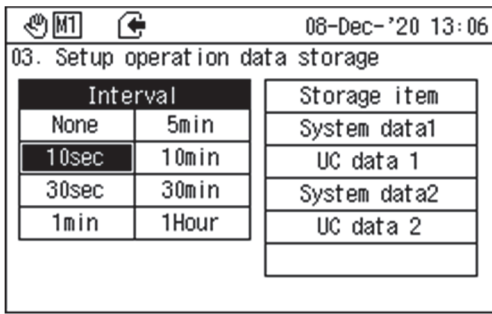

- Select "03. Setup operation data storage" from . The screen on the left appears.
- You can switch the save interval and save items with and .
- You can change the save interval item with and .
- You can change the number of data items to save with and .
- The factory default is to log "System data 1" at an interval of "1 min". Old log entries are overwritten after one month. It is also possible to suppress the overwriting (Contact Toshiba Carrier for details). Keep in mind that logging is disabled when the storage area becomes full. The following table gives ballpark figures for the maximum amount of data that can be stored.

Maximum amount of stored data

Number of connected heat pumps	Save interval	Save period	Saved items	Approximate guide
8	1 minute	24 hours	System data 1	945 months
8	1 minute	24 hours	System data 1 + UC data 1	140 months
8	1 minute	24 hours	System data 1 + UC data 1 + System data 2	133 months
8	1 minute	24 hours	System data 1 + UC data 1 + System data 2 + UC data 2	115 months
16	1 minute	24 hours	System data 1	873 months
16	1 minute	24 hours	System data 1 + UC data 1	70 months
16	1 minute	24 hours	System data 1 + UC data 1 + System data 2	68 months
16	1 minute	24 hours	System data 1 + UC data 1 + System data 2 + UC data 2	58 months

Always use "SD Formatter" to format the SD card.

(Refer to the SD Formatter instructions for details on how to use it.)

URL for download:

[https://www.sdcard.org/jp/downloads/formatter\\_4/eula\\_windows/index.html](https://www.sdcard.org/jp/downloads/formatter_4/eula_windows/index.html)

The following tables show the data that is stored by each storage item.

Group Data 1

Stored data	Symbol	Description
MC data	0_REMOTE	Operating pattern
	0_PTN_NO	Operation pattern
System data	0_SYSNO*	System number (0 to 15)
	0_RUN*	Run/Stop
	0_DND*	Demand
	0_MODNO*	Operation mode number
	0_SET*	Set temperature
	0_FLWMD*	Flow rate control method
	0_CTRUC*	Number of controllable UCs
	0_ALMCD*	Failure codes
	0_PSTG*	Number of operating pumps
	0_UCSTG*	Number of operating units
	0_STAGE*	Operating capacity
	0_OAT*	Average outdoor air temperature
	0_EWT*	Average inlet water temperature
	0_LWT*	Average outlet water temperature
	0_SYSET*	Load side return water temperature
	0_SYSLT*	Load side feed water temperature
	0_SFLW*	Load-side flow rate
	0_FLOW*	Heat source side flow rate
	0_HDP*	Actual DRP
	0_VALVE*	DPR valve opening
0_CAP*	Approximate capacity	

UC Data 1

Stored data	Symbol	Description
UC data	*_REMOTE	Unit/Remote
	*_RUN	Run/Stop
	*_THMCMD	Thermo instruction
	*_MODENO	Operation mode number
	*_SET	Set temperature
	*_ALM	Failure code
	*_STAGE	Operating capacity (%)
	*_EWT	Inlet water temperature
	*_LWT	Outlet water temperature
	*_FLOW	Flow rate
	*_DGP#	High pressure
	*_SGP#	Low pressure
	*_CPRUN#	Compressor running time
*_CPCNT#	Compressor running count	

UC Data 2

Stored data	Symbol	Description
UC data	*_ALT	Alert code
	*_CWT	Middle water temperature
	*_MMX	Pump frequency
	*_EWP	Inlet pressure
	*_LWP	Outlet pressure

Group Data 2

Stored data	Symbol	Description
System data	0_FLWST*	Flow rate control setting ID
	0_GRPUC*	Number of UC belonging to system
	0_ALTCD*	Alert code
	0_RPSTG*	Required number of pumps
	0_RQSTG*	Required number of operating units
	0_RQTHM*	Thermo requirement
	0_RQFLW*	System target flow rate
	0_RQPMP*	Pump instruction (0: Hz/1: flow rate)
	0_DTFW*	Design temperature differential target flow rate
	0_RQPFQ*	Required pump Hz/frequency
0_RQHDP*	Target differential pressure	

04. Data&Time setting screen

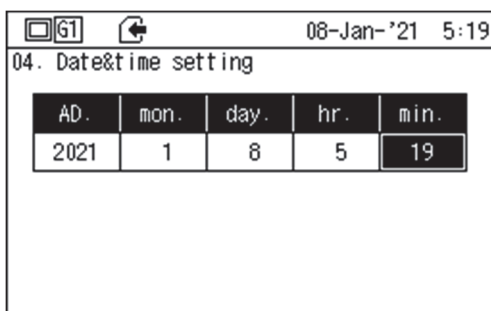

- Select "04. Data&Time setting" from . The screen on the left appears.
- You can change the item with and . You can change the numeric value with and .

05. LCD settings screen

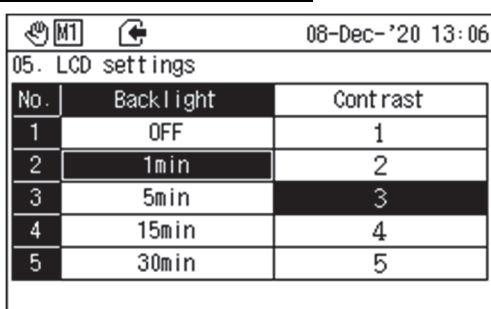

- Select "05. LCD setting" from . The screen on the left appears.
- Press and to switch the "Backlight" and "Contrast". You can change the item with and .

## 06. Password setting screen



- Select "06. Password setting" from . The screen on the left appears.
- The password must be 4 digits. Choose a number between 0000 and 9999.
- You can change the digits with and .
- You can change the numeric value with and .
- When you press , a confirmation screen appears if there are any changes.
- Refer to "When confirming on the message screen" for detailed information about using the confirmation screen.

## 07. DN code setting screen

DN code	Value	Value	Value
042	0	085	15
043	100	086	15
044	2		
045	15		
046	15		
082	0		
083	100		
084	2		

- Select "07. DN code setting" screen from . The screen on the left appears.
- You can change the DN code number with , , , and .
- Press according to the DN code number you want to change. The data entry screen appears.
- Refer to the "Value input" screen for detailed information about entering data.
- When you press , a confirmation screen appears if there are any changes.
- Refer to "When confirming on the message screen" for detailed information about using the confirmation screen.

## List of the DN Codes (MC)

- : Restarts when set
- ▲: Items that can be displayed (can be set) as custom options
- : Items that can be set by the user (standard)

DN code	Description	Initial value	Min.	Max.	Description
14	Continue operation when GC communication failure occurs	1	-1	1	Set whether to continue operation in case of failure in communication with GC. -1: System operation stopped 0: Thermo OFF (minimum number of pumps operating) 1: System continued operation
42	System A: Failure setting at POFF	0	0	1	Set whether to treat it as a failure if system A pump stops during pre-operation. 0: Do not treat as failure 1: Treat as failure
43	System A: Ratio of units with major failures confirmed (%)	100	1	100	Set the failure ratio of UC for system A with major failure confirmed.
44	System A: Operation continues when a major failure occurs	2	0	2	Set whether to continue operation when system A has a major failure. 0: If the ratio of units with major failures confirmed is exceeded, stop operation 1: If all UCs have major failures, stop operation 2: Even when all UCs have major failures, MC continues operation and UC resumes operation after recovery
45	System A: Pump pre-operation time (sec)	15	10	180	Set the pump pre-operation time of system A.
46	System A: Pump remaining operation time (sec)	15	10	180	Set the pump remaining operation time of system A.
82	System B: Failure setting at POFF	0	0	1	Set whether to treat it as an failure if system B pump stops during pre-operation. 0: Do not treat as failure 1: Treat as failure
83	System B: Ratio of units with major failures confirmed (%)	100	1	100	Set the failure ratio of UC for system B with major failure confirmed.
84	System B: Operation continues when a major failure occurs	2	0	2	Set whether to continue operation when system B has major failure. 0: If the ratio of units with major failures confirmed is exceeded, stop operation 1: If all UCs have major failures, stop operation 2: Even when all UCs have major failures, MC continues operation and UC resumes operation after recovery
85	System B: Pump pre-operation time (sec)	15	10	180	Set the pump pre-operation time of system B.
86	System B: Remaining pump operating time (sec)	15	10	180	Set the pump remaining operation time of system B.

# Unit Controller

Explanation of the various display lamps and button for module independent operation of the unit controller

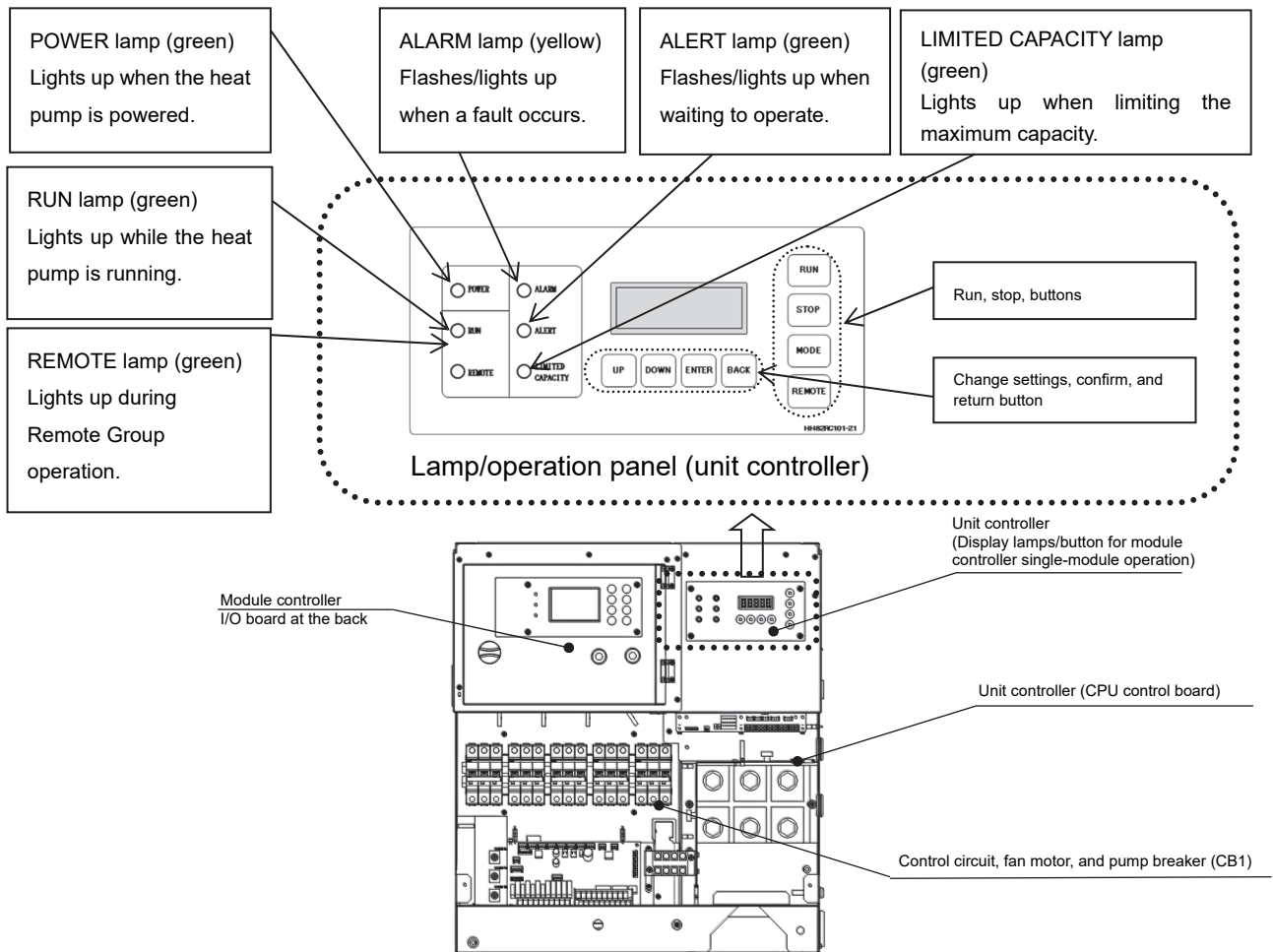

## ■ RUN (Run button)

During remote group operation: Disabled (In accordance with instructions from the module controller.)

During unit module operation: Press RUN to operate the corresponding module.

## ■ STOP (Stop button)

During remote group operation: Press STOP to stop the corresponding module.

The module changes to unit module mode.

During unit module operation: Press STOP to stop the corresponding module.

## ■ MODE (Cooling/heating button) (heat pump module only)

During remote group operation: Disabled (Switching between cooling and heating follows commands from the module controller.)

During unit module operation: Buttons between cooling and heating during single-module operation. (Mode change only possible when the heat pump is not running.)

Note: To perform unit module operation when another module, connected to the same water piping system, is operating (RUN touched), do so in accordance with the operation mode (cooling or heating) of the other module.

## ■ REMOTE (Remote/Unit button)

Switches between remote group operation (control via module controller) and unit module operation (single-module operation).

**(1) Unit Controller display panel buttons - Setting modification buttons (UP/DOWN), confirmation button (ENTER) and the return button (BACK).**

The operation buttons (UP/DOWN and ENTER) and the 5-digit LED display on the unit controller (UC) display panel can be used for operations such as; setting the temperature set-point, monitoring the operational state and displaying the error log for the corresponding module.

When title appears

**UP** ..... Go to the next display title.

**DOWN** ..... Go to the previous display title.

**ENTER** ..... Go to the detailed item.

When detailed item appears

**UP** ..... Go to the next detailed item.

**DOWN** ..... Go to the previous detailed item.

**BACK** ..... Go to the display title.

When changing the setting value of a detailed item

**UP** ..... Increase the setting value.

**DOWN** ..... Decrease the setting value.

**ENTER** ..... Confirm the setting value.

**BACK** ..... Go to the display title.

**(2) Explanation of control mode switches (SW5, SW6, and SW9)**

Use these DIP switches to configure the local control mode setting. Though the control mode setting is configured at the factory, check the setting to ensure that it is compatible with local conditions. Use SW5, SW6 and SW9 on the CPU control board to change the control mode. Before changing it, turn off the power of the control circuit/pump breaker (CB1) inside the power control box and check that the power of the CPU board is shut off. After configuring the setting of each switch, turn the power back on.

(Note 1) Do not change the factory defaults.

However, SW6-7 need to be changed after water filling at the site.

(Note 2) The settings of a custom-made model may differ from the following configuration.

(Note 3) It is set according to the model.

SW No.	Status	Description	
		SW5	SW6
1	ON	(Note 3)	Standard
	OFF	(Note 3)	-
2	ON	(Note 3)	-
	OFF	(Note 3)	Standard
3	ON	Both cooling and heating	Standard
	OFF	Cooling only	-
4	ON	High EER type	-
	OFF	Standard	Standard
5	ON	Integrated inverter pump model	-
	OFF	Pumpless model	Standard
6	ON	Antifreeze specifications	(Note 3)
	OFF	Standard	(Note 3)
7	ON	(Note 3)	Pump operation disabled
	OFF	(Note 3)	Pump operation enabled
8	ON	Standard	-
	OFF	-	Standard

SW5 (Cooling-only module)

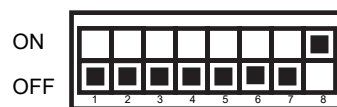

SW5 (Cooling/heating module)

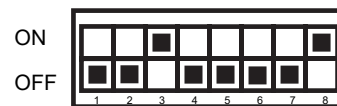

\* Switches 1 and 2 are not shown.

SW6 (Cooling-only and cooling/heating modules)

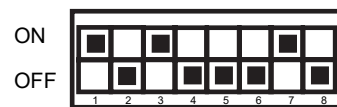

Note 1: Set switch 7 to OFF after water filling is complete. If it is set to OFF before water filling, the pump will run idle in freeze protection mode and may be damaged.

### (3) Various display items and display titles

Item	LED display		
	Display title	Display content	
Operation mode	0. S t A t	COOL/HEAT C□□□/H□□□	Indicates that the operation mode is cooling/heating and that stopped. Indicates that the operation mode is cooling/heating and □ indicates the capacity [%] during operation.
		C□□□/H□□□ =>En○○=>E◇△△	Indicates that a circuit has experienced a minor fault and is stopped. Indicates the Unit mode is selected and operation mode is cooling/heating. □ indicates the capacity [%] during operation. · ◇ indicates the faulty circuit name. Indicates ◇ = 0 (system), A (A circuit), b (B circuit), C (C circuit), d (D circuit). · △ indicates the failure code (hexadecimal).
		STOP=>En○○=>E◇△△	Indicates that a module has experienced a major failure and is stopped. · Display is in order from the item on the left. ○ indicates the order of the failure (decimal). · ◇ indicates the faulty circuit name. Indicates ◇ = 0 (system), A (A circuit), b (B circuit), C (C circuit), d (D circuit). · △ indicates the failure code (hexadecimal).
Set water temperature	1. S E t	SPEC	Indicates the set water temperature (cooling) [°C] on the module controller during remote operation.
		SPEH	Indicates the set water temperature (heating) [°C] on the module controller during remote operation.
		SP-C	Indicates the set water temperature (cooling) [°C] during Unit operation.
		SP-H	Indicates the set water temperature (heating) [°C] during Unit operation.
Chilled (warm) water temperature Outdoor air temperature Relative humidity	2. t H - 1	Et	Indicates the chilled/warm water entering temperature [°C].
		Lt	Indicates the chilled/warm water leaving temperature [°C].
		Ct	Indicates the chilled/warm water intermediate temperature [°C].
		OAt	Indicates the outdoor air temperature [°C].
Refrigerant temperature	3. t H - 2	OAI2	Indicates the relative humidity sensor ambient temperature [°C]. (Note 1)
		tH	Indicates the relative humidity sensor detection value (before correction) [%]. (Note 1)
		dGt.◇	Indicates the discharge gas temperature [°C] of each circuit. ◇= circuit name (A, b, C, d)
		SGt.◇	Indicates the suction gas temperature [°C] of each circuit. ◇= circuit name (A, b, C, d)
		Ct.◇1	Indicates coil gas temperature 1 [°C] of each circuit. ◇= circuit name (A, b, C, d) (heat pump only)
		Ct.◇2	Indicates coil gas temperature 2 [°C] of each circuit. ◇= circuit name (A, b, C, d) (heat pump only)
		Sdt.◇	Indicates the saturated condensation temperature [°C] of each circuit. ◇= circuit name (A, b, C, d)
		SSt.◇	Indicates the saturated evaporation temperature [°C] of each circuit. ◇= circuit name (A, b, C, d)
Failure history	4. H I S t	1◇△△ ∨ 8◇△△	Indicates a history of past failures. · 1 to 8 indicate the failure history order. 1 to 8 indicate the order from newest to oldest. * Indicates ◇=0 (system), A (A circuit), b (B circuit), C (C circuit), d (D circuit). · △ indicates the failure code (hexadecimal).
		<<If error exists>> 1◇△△ ∨ 5◇△△ <<If error does not exist>> _ _ _ _	Indicates all currently detected errors. If a failure reset is performed, the 7-segment display becomes "-_ _ _". This error history "HIST" shows the latest error code in the error indication "Err". · 1 to 5 indicate the order in which failures are detected. 1 to 5 indicate the order from newest to oldest. * Indicates ◇=0 (system), A (A circuit), b (B circuit), C (C circuit), d (D circuit). · △ indicates the failure code (hexadecimal).
Compressor operation time, Compressor startup count, PWM box cooling fan operation time, Pump operation time, Number of pump startups	6. C P C t	Ct.◇	Indicates the compressor operation time [h] of each circuit. ◇= circuit name (A, b, C, d)
		CC.◇	Indicates the compressor startup count [times] of each circuit. ◇= circuit name (A, b, C, d)
		Ft	Indicates the PWM box cooling fan operation time [h].
		PnP.t	Indicates the pump operation time [h].
Approximate current, power	7. ELEP	PnP.C	Indicates the pump start up count [times].
		CU.C.◇	Indicates the approximate current consumption [A] of the compressor of each circuit. ◇= circuit name (A, b, C, d)
		CU.P	Indicates the approximate current consumption [A] of the pump.
Defrost condition	8. d F r C	dC.◇	Indicates the DC voltage [V] of the compressor of each circuit. ◇= circuit name (A, b, C, d)
		dFS.◇	Indicates the number of circuits that displays the defrost stage. ◇= circuit name (A, b, C, d) After this indication, defrost stage "STGO" or "FFFF" (no defrost judgement) is displayed.
Refrigerant pressure	9. PrES	dGP.◇	Indicates the condensation pressure [MPa] of each circuit. ◇= circuit name (A, b, C, d)
		SGP.◇	Indicates the evaporation pressure [MPa] of each circuit. ◇= circuit name (A, b, C, d)
Chilled (warm) water pressure, Converted flow rate	A. FLO	EP	Indicates the chilled (warm) water entering pressure [kPa].
		LP	Indicates the chilled (warm) water leaving pressure [kPa].
		SP	Indicates the pressure on the intake side of the pump (Models with integrated pump only)
		FLO	Indicates the converted flow rate [L/min] of chilled (warm) water calculated from the pressure difference between chilled (warm) water entering and leaving.
State of each control element	b. ELEt	C.F.◇	Indicates the compressor operation frequency [Hz] of each circuit. ◇= circuit name (A, b, C, d)
		F.r.◇	Indicates the fan revolution speed [rpm] of each circuit. ◇= circuit name (A, b, C, d)
		EP.◇1	Indicates the degree of opening [pulse] of expansion valve 1 of each circuit. ◇= circuit name (A, b, C, d)
		EP.◇2	Indicates the degree of opening [pulse] of expansion valve 2 of each circuit. ◇= circuit name (A, b, C, d)
		IEP.◇	Manual operation of expansion valve ◇= circuit name (A, b, C, d)
		PnP.F	Indicates the pump frequency [Hz]. (Pump-integrated machine only)
DN code setting	C. d n S t	d-○○○	Indicates the DN code that can be set. ○○○ = DN code number (hexadecimal number) After the desired DN code is selected, its setting value appears.
Data before fault	d. E S t S	Ct	Indicates the faulty circuit number.
		Et	Indicates the chilled (warm) water entering temperature [°C] immediately before the unit stopped due to a fault.
		Lt	Indicates the chilled (warm) water leaving temperature [°C] immediately before the unit stopped due to a fault.
		Ct	Indicates the chilled (warm) water intermediate temperature [°C] immediately before the unit stopped due to a fault.
		Oat	Indicates the outside air temperature [°C] immediately before the unit stopped due to a fault.
		dGP	Indicates the condensation pressure [MPa] of the faulty circuit immediately before the unit stopped due to a fault.
		SGP	Indicates the evaporation pressure [MPa] of the faulty circuit immediately before the unit stopped due to a fault.
		dGt	Indicates the discharge gas temperature [°C] of the faulty circuit immediately before the unit stopped due to a fault.
		SGt	Indicates the suction gas temperature [°C] of the faulty circuit immediately before the unit stopped due to a fault.
		Ct.1	Indicates coil gas temperature 1 [°C] of the faulty circuit immediately before the unit stopped due to a fault. (Heat pump-integrated machine only)
		Ct.2	Indicates coil gas temperature 2 [°C] of the faulty circuit immediately before the unit stopped due to a fault. (Heat pump-integrated machine only)
		tH	Indicates the heat sink temperature [°C] of the faulty circuit immediately before the unit stopped due to a fault.
		SEtP	Indicates the setpoint water temperature [°C] of the faulty circuit immediately before the unit stopped due to a fault.
		C.F	Indicates the compressor operation frequency [Hz] of the faulty circuit immediately before the unit stopped due to a fault.
		EP.1	Indicates the degree of opening [pulse] of expansion valve 1 of the faulty circuit immediately before the unit stopped due to a fault.
		EP.2	Indicates the degree of opening [pulse] of expansion valve 2 of the faulty circuit immediately before the unit stopped due to a fault.
		F.r.S	Indicates the fan rotation speed [rpm] of the faulty circuit immediately before the unit stopped due to a fault.
		dC	Indicates the DC voltage [V] immediately before the unit stopped due to a fault.
Cn	Indicates the presence or absence of boosting voltage control when the unit stopped due to a fault.		
StP.dC	Indicates the standard DC voltage [V] immediately before the unit stopped due to a fault.		
PnP.F	Indicates the pump frequency [Hz] immediately before the unit stopped due to a fault.		
For service	E. CodE	(Service mode)	Indicates the operation mode for inspection.
Special specifications	F. OPT	(Special specifications)	Use for special specifications.

Note 1: If the corresponding module relative humidity sensor is not connected, "-99.9" appears.



◆ Various display item operation examples

- Example to change the display title

You can use UP or DOWN to change the display title.

Example) 0. StAt → **UP** → 1. Set

- Example to change the setting value of a detailed item

After changing the display title, you can touch ENTER to display the detailed item and then display the setting value. You can use UP or DOWN to change the detailed item. Also, you can return to the title display by touching BACK from the detailed item screen.

When entering water temperature is 20°C and leaving water temperature is 10°C

Example) 2. tH-1 → **ENTER** → Et → 20 (Display detailed item)

Et → 20 → **UP** → Lt → 10 (Change the detailed item)

Et → 20 → **BACK** → 2. tH-1 (Return to the title display)

- Example to change the setting value of a detailed item (unit module operation)

After displaying the setting value of the detailed item, touch ENTER to make the setting value flash. Change the setting value with UP or DOWN while it flashes and then confirm the setting with ENTER. After changing the setting value, touch BACK to return to the detailed display screen.

When changing the set water temperature (cooling) from 7°C to 6.8°C

Example) SP-C → 7.0 → **ENTER** → "7.0" → **DOWN** → "6.8"

1.Set ← **BACK** ← 6.8 ← **ENTER**

(4) DN code table based on pump horsepower difference

\* After delivery of the heat pump, check to ensure the pumps horsepower setting of the DN code correlates to the heat pump's nameplate.

DN code	Function	Pump HP	Setting value
CF	Pump HP setting	1.5 kW (50 HP , 60 HP standard)	2
		2.2 kW (70 HP standard)	3
		3.7 kW	4
		5.5 kW	5
		7.5 kW	6

Checking and setting DN code

1. Use UP and DOWN to select "C.dnSt", and then ENTER to confirm.
2. After d-○○○ appears, the set value appears. After "d-○○○" appears, the shown DN code number is indicated. The set value is shown in "●".

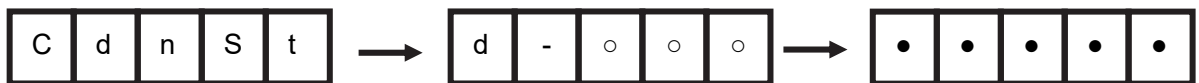

3. Use UP and DOWN to change the DN code number. When a desired DN code number (d-0CF) is selected, the value for each horsepower as listed in the table also appears. Check that the pump horsepower indicated on the installed pump name plate is the same as the pump horsepower value displayed.
4. If they are different, change the displayed value, as follows:
  - Touch ENTER to confirm. The value flashes so that you can change it.
  - When the value is still flashing, use UP and DOWN to change the displayed value to the correct value for the pump horsepower, and then touch ENTER to confirm.
5. Finally, use BACK to return to the default value such as "Cool".



# Unit Controller (with pressure display function)

A unit controller with pressure display function supports only the factory default.

This section explains the unit controller's various display lamps, button for single-module operation, and operation state.

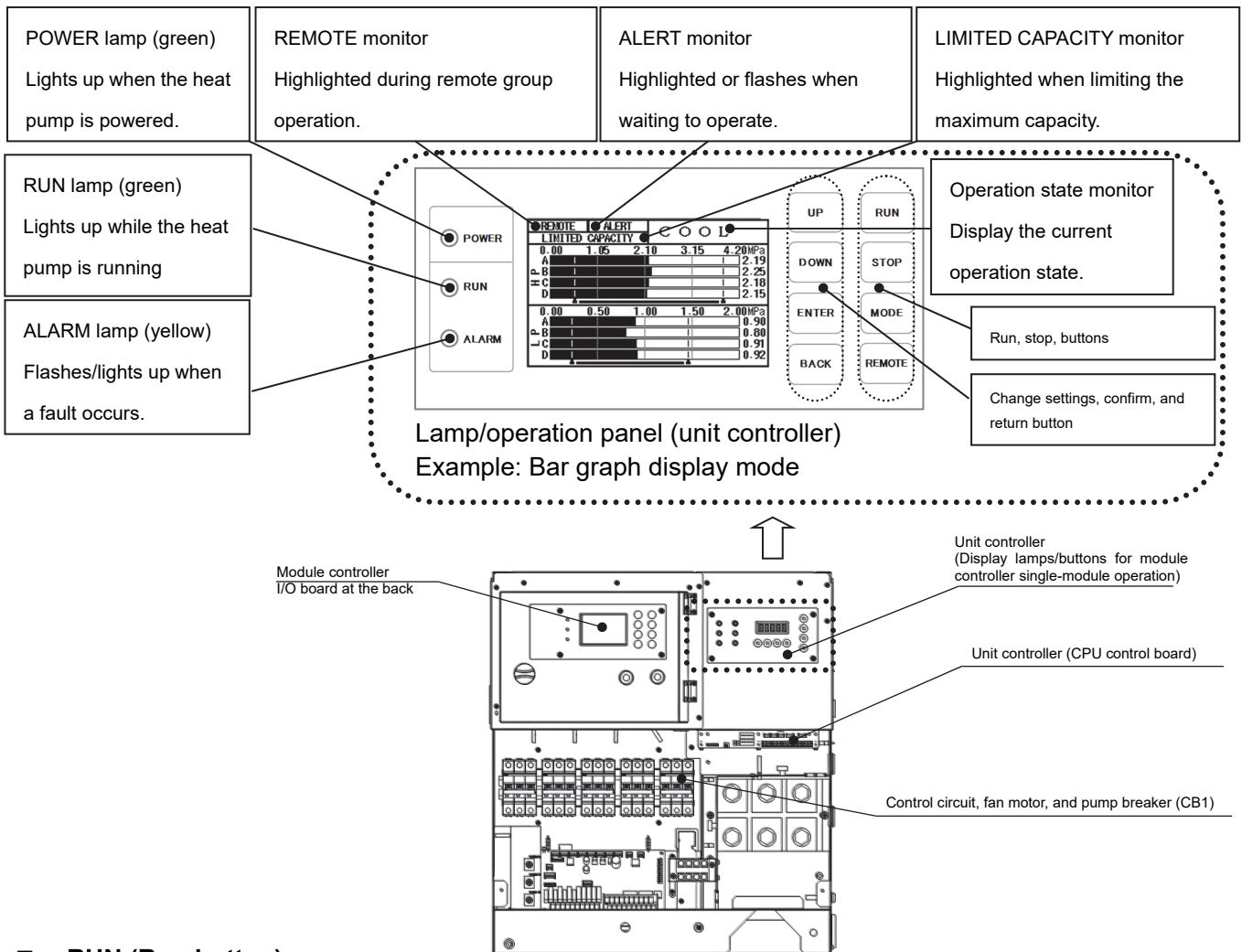

## ■ RUN (Run button)

During remote group operation: Disabled (In accordance with instructions from the module controller.)

During unit module operation: Touch RUN to operate the corresponding module.

## ■ STOP (Stop button)

During remote group operation: Touch STOP to stop the corresponding module.

The module changes to unit module mode.

During unit module operation: Touch STOP to stop the corresponding module.

## ■ MODE (Cooling/heating button)(heat pump module only)

During remote group operation: Disabled (Switching between cooling and heating follows commands from the module controller.)

During unit module operation: Switches between cooling and heating during single-module operation. (Valid only when the heat pump is off.)

Note: To perform unit module operation when another module, connected to the same water piping system, is operating (RUN touched), do so in accordance with the operation mode (cooling or heating) of the other module.

## ■ REMOTE (Remote/Unit button)

Switches between remote group operation (control via module controller) and unit module operation (single-module operation).

**Setting modification buttons (UP, DOWN), confirmation button (ENTER), return button (BACK)**

The operation buttons (UP, DOWN, and ENTER) and LED display on the operation panel (unit controller with pressure display function) can be used for operations such as setting the temperature setpoint, monitoring the operation state, and displaying the error log for the corresponding module.

When title appears

**UP** ..... Go to the next display title.

**DOWN** ..... Go to the previous display title.

**ENTER** ..... Go to the detailed item.

When detailed item appears

**UP** ..... Go to the next detailed item.

**DOWN** ..... Go to the previous detailed item.

**BACK** ..... Go to the display title.

When changing the setting value of a detailed item

**UP** ..... Increase the setting value.

**DOWN** ..... Decrease the setting value.

**ENTER** ..... Confirm the setting value.

**BACK** ..... Go to the display title.

◆ **Display mode**

The unit controller with pressure display function displays the operating pressure of each circuit. The display mode can be set to one of Bar Graph Display, Numerical Display 1, and Numerical Display 2.

**(1) Bar graph display (standard settings)**

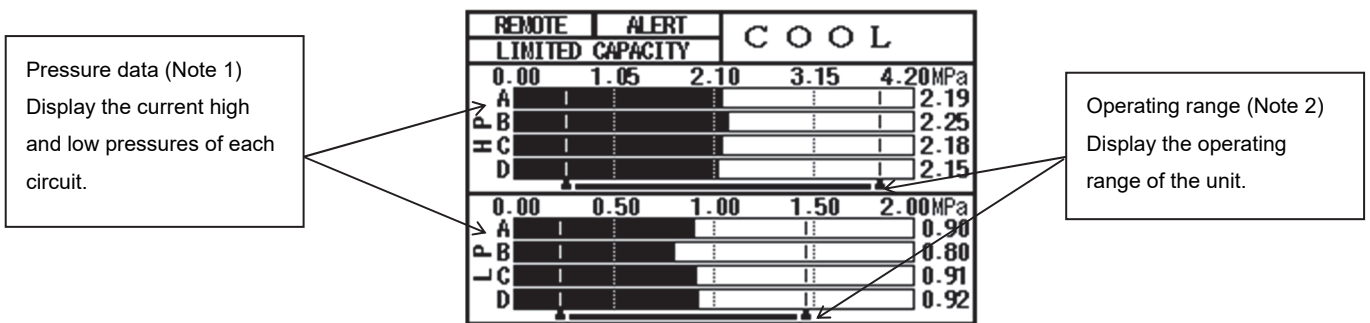

**(2) Numerical display 1**

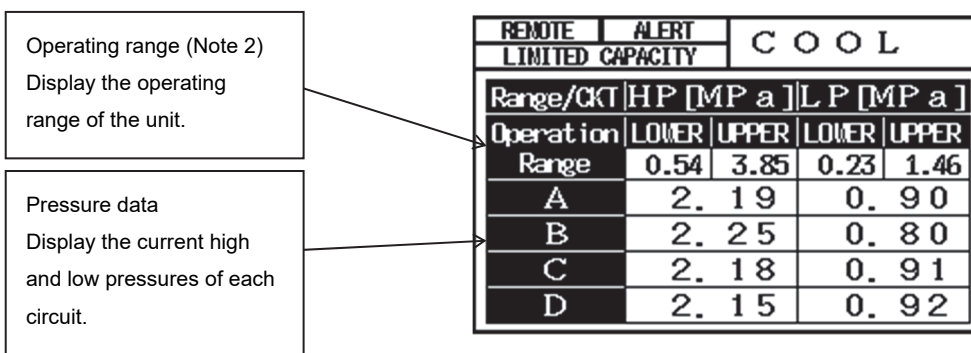

### (3) Numerical display 2

Pressure data  
Display the current high and low pressures of each circuit.

REMOTE	ALERT	LIMITED CAPACITY
C O O L		
CIRCUIT	HP [MP a]	LP [MP a]
A	2.19	0.90
B	2.25	0.80
C	2.18	0.91
D	2.15	0.92

Note 1: Graph scale interval, maximum value, minimum value of bar graph display can be changed.

Note 2: Operating range display can be changed.

Note 3: When the power supply is turned off, the pressure values will not be displayed.

#### ◆ Display settings

The graph scale interval, minimum/maximum value of display setting and bar graph ranges can be changed via the DN codes shown below.

DN code	Description	Initial value	Setting range	
			Minimum	Maximum
1A0	Contrast	2	0	4
1A1	Backlight OFF time [min] 0: Always on	0	0	60
1A2	Pressure display mode 0: Graph 1: Numerical value 1 2: Numerical value 2	0	0	2
1A3	Graph scale division number	4	4	7
1A4	High pressure graph range upper limit [MPa]	4.20	0.00	4.50
1A5	High pressure graph range lower limit [MPa]	0.00	0.00	4.50
1A6	High pressure operation range upper limit [MPa]	3.85	2.00	4.50
1A7	High pressure operation range lower limit [MPa]	0.54	0.00	2.50
1A8	Low pressure graph range upper limit [MPa]	2.00	0.00	3.50
1A9	Low pressure graph range lower limit [MPa]	0.00	0.00	3.50
1AA	Low pressure operation range upper limit [MPa]	1.46	0.50	3.00
1AB	Low pressure operation range lower limit [MPa]	0.23	0.00	2.50

#### Checking and setting DN code

- Use UP and DOWN to select "C.dnSt", and then ENTER to confirm.
- After d-○○○ appears, the set value appears. After "d-○○○" appears, the shown DN code number is indicated. The set value is shown in "●".

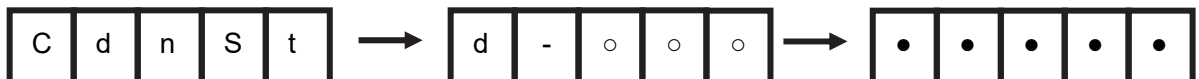

- Use UP and DOWN to change the DN code number. When a desired DN code number (d-0CF) is selected, the value for each horsepower as listed in the table also appears. Check that the pump horsepower indicated on the installed pump name plate is the same as the pump horsepower value displayed.
- If they are different, change the displayed value, as follows:
  - Touch ENTER to confirm. The value flashes so that you can change it.
  - When the value is still flashing, use UP and DOWN to change the displayed value to the correct value for the pump horsepower, and then touch ENTER to confirm.
- Finally, use BACK to return to the default value such as "Cool".

# Main Functions

## 1. Automatic control functions

### **Cooling and heating operations**

This heat pump starts a refrigeration cycle using compressors and optimizes the cycle to produce chilled or warm water by controlling the opening of electric expansion valves and the speed of fans. It adjusts the number of compressors to be activated and their operation frequency to make the leaving water temperature close to a setpoint.

(Note)

In a low outdoor air temperature or snowy environment, it takes some time for the leaving water temperature to reach a setpoint after a heating operation starts.

### **Rotation control** => See page 47.

The module controller provides rotation control, which preferentially runs the modules with the least cumulative run hours to evenly distribute operations across all modules. Additionally, each module preferentially runs the compressors with the least cumulative run hours to evenly distribute operations across all its compressors.

### **Flow rate control** => See page 47.

The module controller calculates the flow rate required by the load side and adjusts the number of inverter pumps to be activated in each module and their operation frequency.

(Note)

Some systems do not support flow rate control based on the flow rate requirement of the load side. For these systems, the module controller must be configured for fixed-frequency operation.

### **Freeze protection operation** => See page 49.

When compressors are not running, the fracturing of water heat exchangers, pumps and other devices may occur due to a drop in outdoor air temperature. To prevent this problem, the module controller monitors the water entering/leaving and evaporation temperatures to control the starting and stopping of internal and external pumps.

### **Group control over external pumps** => See the Installation Manual.

The heat pump and external water pumps are linked together.

(Note)

Before activating group control of external pumps, ensure that water is present in pipes for pipe protection. Ensure that the water circuit is not isolated by the solenoid valve.

### **Distributed defrosting control** => See page 48.

In the Heating mode, the unit controller determines frost formation on the air heat exchanger in each circuit and performs defrosting. The four circuits in a given module perform a defrost operation alternately to reduce a drop in warm water temperature during defrosting.

(Note)

The module controller does not prohibit simultaneous defrosting by multiple modules. Therefore, multiple modules can perform a defrost operation at the same time. For 60HP (Powerful heating type), however, there is an upper limit on the number of modules to be defrosted at the same time, and it is difficult for the warm water leaving temperature during defrosting to decrease. In addition, 60HP (Powerful heating type) determines the frosted state including the relative humidity.

### **Protection control for risk distribution**

Risk diversification on the heat pump means that the unit controller can determine whether the module can continue to operate based on the state of the protective devices and various sensors. If any given circuit in a module has stopped due to a protection device activating, one of the other circuits in that module will automatically operate to initiate the circuit back up operation. In the event of all circuits in a module failing, any given module in the system will start up in the module back up operation.

### **DRP bypass valve control** \* Available only with single pump system

If you enter header-to-header pressure difference in the module controller, it controls the opening of the DRP bypass valve according to the load.

\*Depending on the system, it may not be possible to implement control with a heat pump pressure sensor. In such cases it is possible to implement control by entering the differential pressure between headers into the module controller.

### **Heater control** \* 60HP (Powerful heating type)

By detecting the outside air temperature and by controlling the heater of the drain pan, it prevents freezing of the drain water.

## 2. Status display and output signalling functions

### **Operation status display and signalling**

The module controller show the Run/Stop state of the heat pump on the LCD screen. These controllers also provide the start signal that can be used by an external Run/Stop indicator (close during operation and open otherwise).

### **Error display and signalling**

The module controller show the error status of the heat pump on the LCD screen. These controllers also provide the Major - and Minor -error signals that can be used by an external error indicator or buzzer (Closed contact when an error occurs and open contact for normal operation).

### **Operation pattern display and signalling**

The module controller show the state of the operation pattern on the LCD screen. These controllers also provide operation pattern signals for external status monitoring.

### **Operation mode display and signalling**

The module controller show the current operation mode (Cooling/Heating/Cooled Thermal Energy Storage/Heated Thermal Energy Storage) on the LCD screen. The module controller also provides a signal for external status monitoring. (The group controller can be optionally customized to support operation mode signalling for each group area.)

### **Operation capacity display and signalling**

The module controller show the operation capacity on the LCD screen. These controllers also provide an operation capacity indication (0 to 100%) for external status monitoring.

\* Under a high outdoor temperature and other conditions, the operating capacity may not become 100% due to operating current suppression control.

### **Approximate capacity display and signalling**

The module controller and the optional group controller LCD screens show the instantaneous power capacity estimated from the refrigerant pressure for each circuit, the current for each circuit etc. Both of these controllers also provide an instantaneous capacity indication for external status monitoring.

**Approximate capacity and power consumption display** \* Available only with the group controller.

=> See the Group Controller Instruction Manual.

The optional group controller shows on the LCD screen the capacity and power consumption of the product of instantaneous capacity multiplied by instantaneous input both estimated from the current, etc. within the group controller.

**Cumulative operation hours and start-up count display**

The module controller shows the cumulative hours of operation and the number of compressor start-ups on the LCD screen on a module-by-module and compressor-by-compressor basis.

**Operating spray signalling**

The module controller provides a signal that indicates the status of the spray for external status monitoring (close when at least one spray is operating and open when all the sprays are off).

**Other output signalling (module controller customization)**

- (1) Group output for peripheral devices: Use it to group together a heat pump and peripheral devices such as air conditioners.
- (2) Group output for defrosting: Use it to provide a signal that indicates defrosting is being performed (Closed contact to show defrost operation and open contact for normal operation).
- (3) Output for freeze protection pump operation: Use it to provide a signal that indicates the pump is performing freeze protection operation (Closed contact to show freeze protection operation and open contact for normal operation).
- (4) Output at maximum-capacity operation: Use it to provide a signal that indicates that the heat pump is operating at its maximum capacity (Closed contact to show maximum capacity operation and open contact for normal operation).
- (5) External heater output: Heater ON/OFF can be output by the outside air temperature.

3. Setting functions • Input function

**Unit/External/Remote**

You can configure Unit, External and Remote operations on the LCD screens of the module controller.

Unit	External	Remote
LCD screen	External contact input	Group controller

**Temperature setpoint**

You can change the leaving water temperature on the LCD screen of the module controller. You can also change the temperature setpoint externally if you configure and connect an input port.

### **Run/Stop**

You can run and stop the heat pump on the LCD screen of the module controller. You can also run and stop the heat pump externally if you connect a wire (continuous signal) to the specified input port. This input port can be configured to accept a pulse signal (with a width of 500 ms or longer).

### **Operation pattern**

You can program an operation pattern on the LCD screen of the module controller. You can also change an operation pattern externally if you connect a wire to the specified input port.

### **Enabling of independent operations for each group**

You can allow independent operations of the modules for each group externally by connecting wires to the specified input ports of the module controller (Closed contact to enable independent operation and open contact for normal operation). This feature is available only when the operating mode is External on the module controller.

### **Demand operation**

The module controller can accept an external demand command if you connect a wire to the specified input port (Closed contact to enable demand operation and open contact for normal operation).

### **Pump interlock**

You can enable pump interlock detection if you connect a wire to the specified input port of the module controller.

### **Double setpoints**

This feature is available if you program an operation pattern with the module controller.

### **Forced fan operation**

It is used to forcibly operate the fan by instructions of snowfall sensor, etc. in order to prevent snowfall to the heat pump.

### **Other inputs (module controller customization)**

- |   |  |
|---|--|
| (1) External capacity input:                  | Run the heat pump at a capacity specified by an external controller.   |
| (2) Maximum module count:                     | Limit the number of modules that can be activated simultaneously.  |
| (3) Demand capacity:                          | Allow the demand capacity to be changed externally.  |
| (4) Auto recovery from a power failure:       | Recover normal operation automatically upon restoration of power after instantaneous power interruption.<br>For details, see the section "Auto recovery from power failures (customization)" on page 59. |
| (5) Linking of the freeze protection pump:    | Activate the pump for freeze protection according to an external instruction.  |
| (6) Signal for mixed use of other heat pumps: | This is used to automatically switch the operation from PQ control or bypass 0 control to staircase variable water flow when operating together with other heat pumps in the same water piping system.   |

#### 4. Functions of group controller (sold separately)

Function items	Item				
Status display	Operation display, warning, operation pattern display, operation mode display, operation capacity display, simple capacity display, simple input display, simple thermal energy and integrated power display				
Output display	Operation output, fault output, operation pattern output, Operation mode output <sup>(*1)</sup> , operation capacity output, simple capacity output, simple input/output				
Unit/External/ Remote Function	<table border="1"> <thead> <tr> <th>Unit</th> <th>External</th> </tr> </thead> <tbody> <tr> <td>On LCD screen</td> <td>External contact input</td> </tr> </tbody> </table>	Unit	External	On LCD screen	External contact input
Unit	External				
On LCD screen	External contact input				
Setting functions	Set temperature, ON/OFF, configuration operation pattern Demand operation <sup>(*2)</sup> , double set point Scheduled operation <sup>(*2)</sup> , energy-saving setting <sup>(*2)</sup>				

(\*1) The group controller's operation output by system is a custom option.

(\*2) Setting options may vary depending on the model of the group controller.



# Control Flow

## 1. Group of modules control

The module controller provides group control over multiple modules.

### (1) Controlling the number of modules by detecting the flow rate

The module controller detects the flow rate required by the load side to determine how many modules need to be operated. It provides rotation control, which prioritizes modules with the shortest cumulative running hours to balance running hours among all modules. The required flow rate is determined as follows:

#### [Duplex pump system]

The module controller measures the temperature balance via the entering and leaving thermistor sensors for water temperature inside the heat pump and the thermistor sensors for water temperature on the supply and return pipes (external sensors attached to the module controller). Based on this measurement, the module controller determines the number of modules to be operated and their respective flow rates in such a way as to minimize the imbalance between the estimated load-side flow rate requirement and the heat pump-side flow rate.

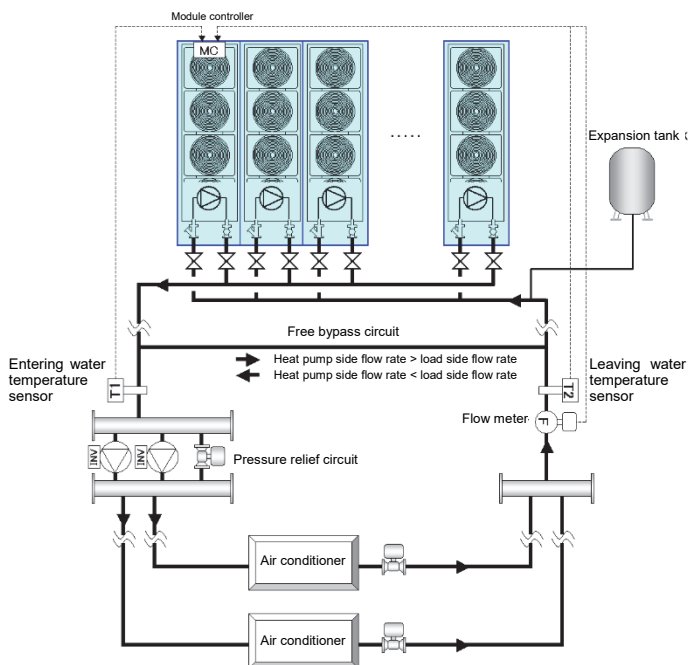
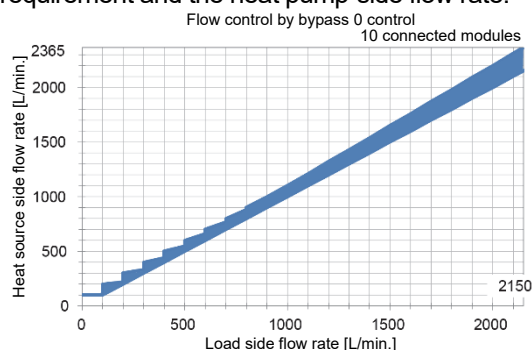

#### [Single pump system]

The module controller measures the temperature balance via the entering and leaving thermistor sensors for water temperature inside the heat pump and the thermistor sensors for water temperature on the supply and return pipes (external sensors attached to the module controller). Based on this measurement, the module controller determines the number of modules to operate and their respective flow rates in such a way as to make the water flow close to the estimated load-side flow rate.

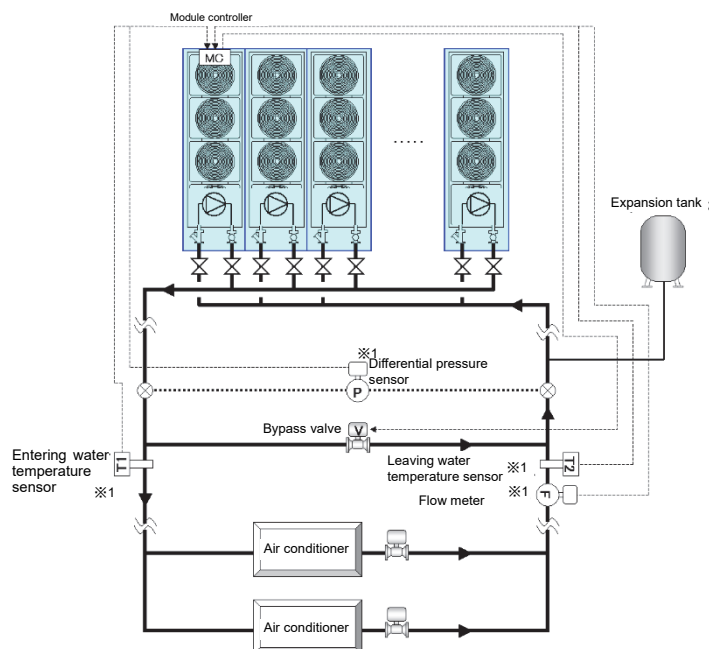
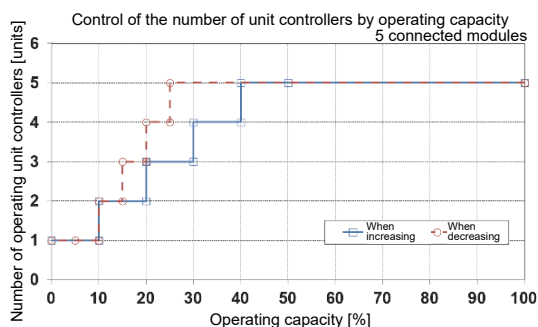

※1 You can perform variable flow rate control even without sensors. You can connect to the MC to perform tasks such as measuring the amount of heat on the load side.

※2 If a system has a flow meter, module control based on a direct measurement of the load-side flow rate can be made possible by connecting the flow meter output to the module controller. Flow rate measurement using thermistor sensors for water temperature incur sensing delays and errors: thus in cases where the bypass pipe is narrow or load fluctuations are fast, the internal pumps may stall, resulting in an abnormality such as a low flow rate error. For this reason, use of a flow meter is recommended. See the Installation Manual for module control for other types of system such as those in which: a) a water piping system is associated with multiple USX groups, b) this heat pump is used together with another model, or c) the system is a constant-flow system.

## (2) Controlling the compressors and pumps of a single module

Control the unit controller that has received operational commands from the module controller as follows.

### [Compressors]

The unit controller controls the number of compressors and operation frequency in such a way as to make the leaving water temperature close to the setpoint. It provides rotation control, which prioritizes compressors with the shortest cumulative running hours to balance running hours among all compressors. (When two compressors are necessary, either one of the downstream circuits (circuits A and B) and either one of the upstream circuits (circuits C and D) are operated.)

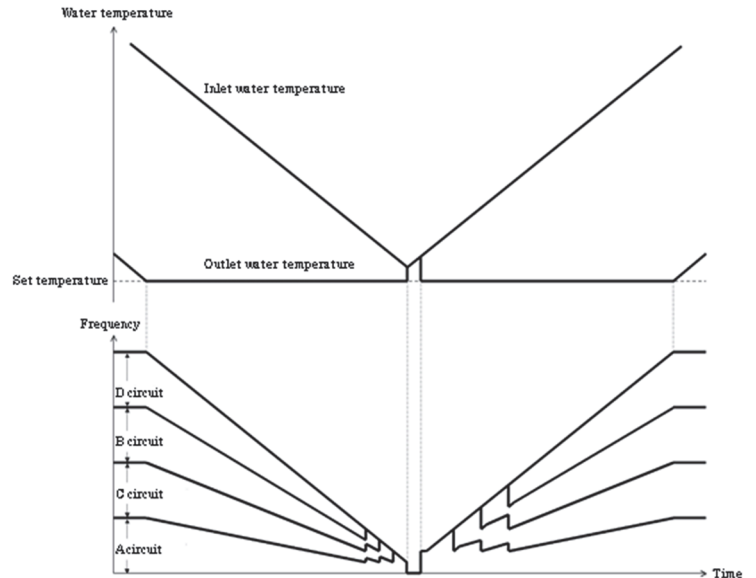

### [Pump]

The module controller provides a flow rate target to each module. The unit controller controls the operation frequency to make its flow rate close to the target.

#### When operating pump at constant speed:

Operates up to a preset fixed frequency. The fixed frequency is set during initial start-up.

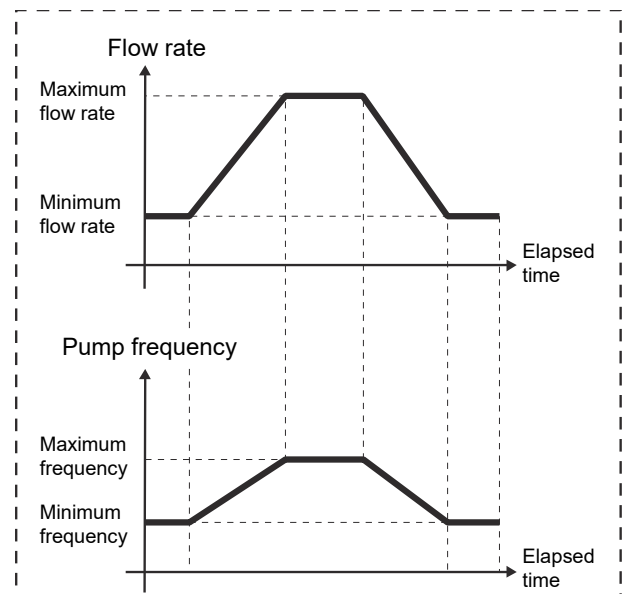

### (3) Capacity control over group of modules

#### [Capacity control at low loads]

At low loads, the module controller increases or decreases the number of active modules to maintain the balance between high-efficiency operation using as many heat exchangers as possible and the flow rates of the modules for pump control.

In the medium-to-high load region, the module controller controls the operation frequency to adjust the amount of feed water from the pumps and the compressor operation capacities according to the load.

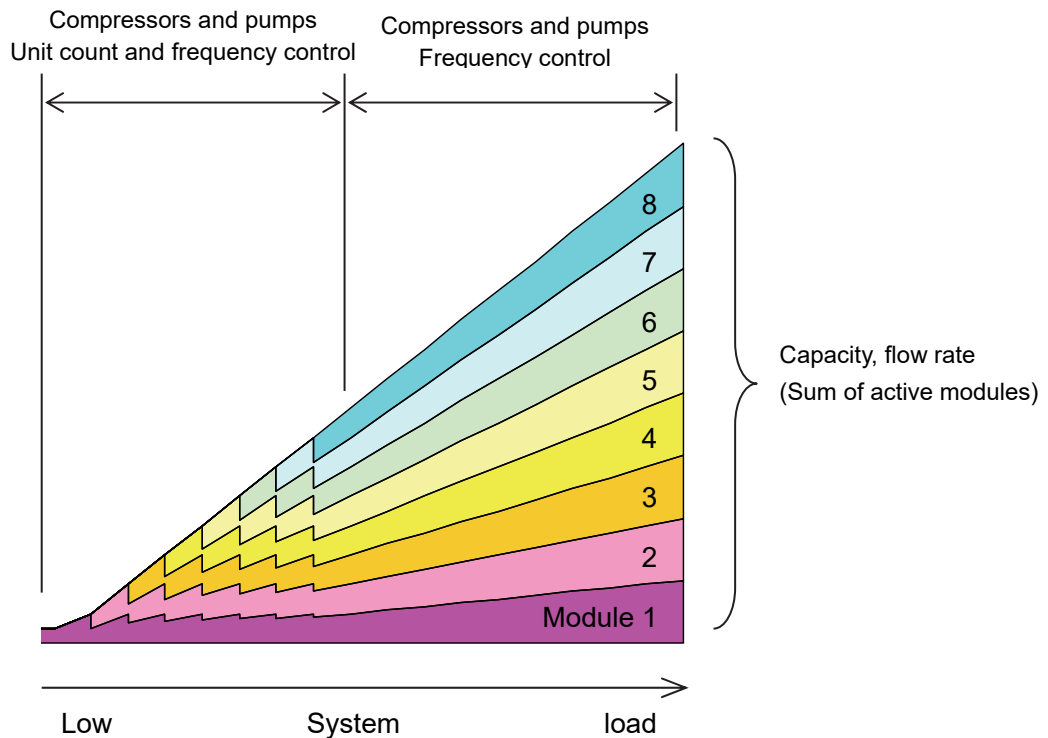

#### [Increasing the capacity at startup]

The module controller determines the number of modules to be operated simultaneously according to the flow rate required by the load side. At high loads (i.e., when a high flow rate is necessary), all modules are started at the same time; in this case, all the modules activate their respective first compressor at the same time and then the second to fourth compressors at the same time. At these stages, the compressors maintain the operation at a constant frequency for a fixed time of period, going up to the maximum performance eventually.

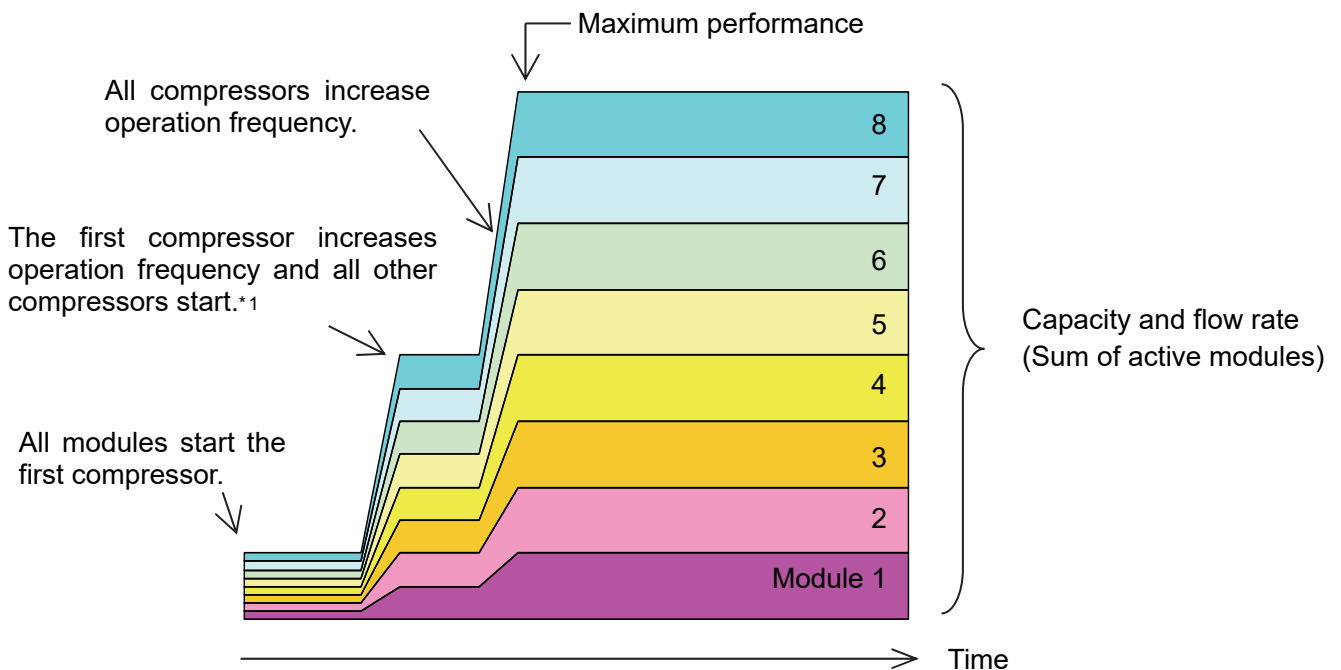

\*1 After start-up, compressors are held at a constant frequency for a given time.

## 2. Defrosting operation control

In the Heating mode, the unit controller predicts frost formation on the air heat exchanger of each circuit and starts defrosting as necessary.

### (1) Control to prohibit simultaneous defrosting

Each module independently performs defrosting. One circuit is defrosted at a time in a given module.

Note: The unit controller provides no control over simultaneous defrosting by multiple modules. Thus, multiple modules can perform defrost operation at the same time.

For 60HP (Powerful heating type), however, there is an upper limit on the number of modules to be defrosted at the same time, and it is difficult for the hot water outlet temperature during defrosting to decrease.

### (2) Starting defrosting

The unit controller determines the frost formation on the air heat exchanger, based on the difference between outdoor air and evaporation temperatures. When the amount of frost on a given circuit has reached a predefined threshold, it starts defrosting. Once defrosting of a circuit is completed, subsequent defrost operation will not be performed on that circuit for the programmed minimum defrosting interval (default: 20 minutes).

However, for 60HP (Powerful heating type), its frosted state including the relative humidity is assessed.

### (3) Completion of defrosting

The unit controller quits defrosting when the condensing temperature has risen above the programmed temperature. The defrosting operation will also end if the maximum defrosting operation time (10 minutes) is exceeded after the start of the defrosting operation.

### (4) Defrosting sequence

In a defrosting operation, each control device operates as follows:

- 1: If none of the circuits of a module is performing defrosting, the unit controller begins preparation for defrosting for a relevant circuit, which consists of stopping the compressor and the fan, and switching the four-way valve from a heating cycle to a cooling cycle.
- 2: Approximately 30 seconds after step 1, the compressor is started. Although fans are basically stopped during defrosting, they may be operated to prevent high-pressure cut-out.
- 3: The compressor is stopped when the predefined defrosting conditions are met. The four-way valve is switched from a cooling cycle back to a heating cycle.
- 4: Approximately 50 seconds after step 3, the compressor runs and the heating operation is resumed.

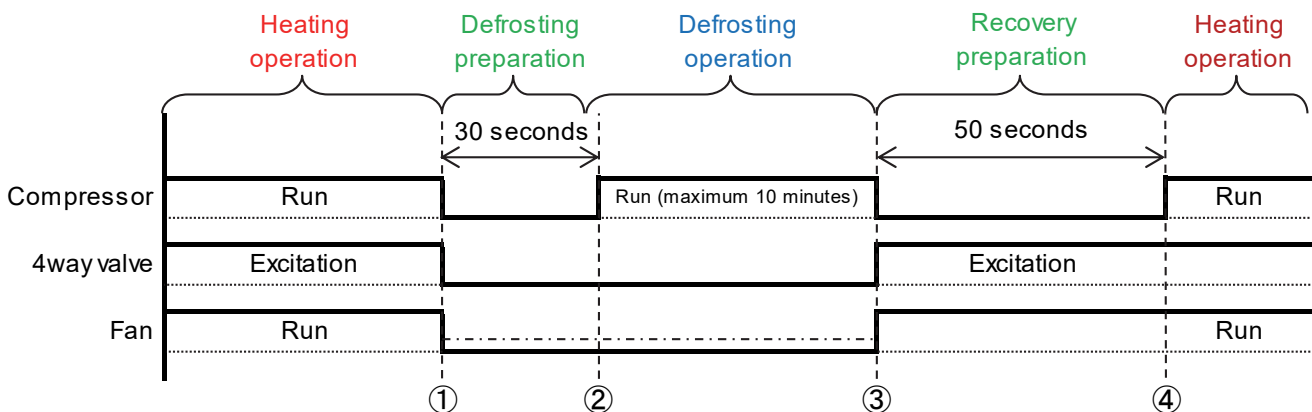

### 3. Pump control

The unit controller adjusts the rotation speed of a pump inside each module using an inverter, as directed by the module controller. For details, see the section "Group of modules control" (P.47).

The following sections describe other pump controls.

#### (1) Preceding and succeeding pump operations

When an operation command from the module controller is received, the unit controller performs a pre-operation of the pump before starting up the compressor. The first pump starts. For the second and subsequent pumps, start as necessary. The minimum time guard from the start of the pump till the compressor operation is 35 seconds.

When a stop command from the module controller is received, the unit controller stops the compressor then stops the pump operation. This is performed at the average frequency of the operating pumps. For cooling operation, the succeeding pump operation time automatically changes based on the low-pressure conditions after the stoppage of the compressor.

##### <During cooling operation>

- The unit controller stops the pump if a low-pressure condition (evaporation temperature) persists at over the freeze prevention temperature for 15 seconds or longer.

##### <During heating operation>

- The pump stops after completing 15 seconds of succeeding operation at the earliest.

#### (2) Freeze protection operation

In order to protect the water heat exchanger from freezing, the unit controller controls the starting and stopping of the pump, based on the entering and leaving water temperature and the evaporation temperature.

\* When preventing freezing, the pump runs at 150 [L/min] (minimum flow rate) per module.

##### <Pump operation conditions>

- Condition 1 (when the detected evaporation temperature is higher than the freeze prevention temperature)
  - Stopping: Entering/leaving water temperature < 2°C (freeze prevention temperature)
  - When the thermo is off (at an operation capacity of 0%): Entering/leaving water temperature < 3°C (freeze prevention temperature + 1°C)

\*1 Freeze prevention errors are not detected for 30 seconds after the pump is started for freeze prevention purpose.

- Condition 2 (When the detected evaporation temperature is less than the freeze prevention temperature)
  - Entering/leaving water temperature < 4°C (freeze prevention temperature + 2°C)
- Condition 3 (Intermittent operation)
  - Detected evaporation temperature is < 0°C and 30 minutes have passed since pump was last stopped

\*2 Evaporation temperature and stopping time can be altered according to installation conditions.

##### <Pump stop conditions>

- When pump starts as result of condition 1: Entering/leaving water temperature > 5°C (freeze prevention temperature + 3°C)
- When pump starts as result of condition 2: Entering/leaving water temperature > 7°C (freeze prevention temperature +5°C)  
or when the pump has continuously run for 20 minutes or more.

\*3 The default freeze prevention temperature is 2°C.

- When pump is started under Condition 3: When pump operation time is 30 seconds or more

\*4 Operating time can be altered according to installation conditions.

Note: If you are using peripheral equipment, it may be necessary to implement measures, such as using an external signal to run the pump to prevent it from freezing if there is a large drop in temperature in equipment other than the heat pump. For details, contact Toshiba Carrier.

### (3) Group control over external pumps

When pump group control is selected, the heat pump and the external chilled (warm) water pump are grouped together. As shown below, the external pump starts at least 15 seconds before the compressor and continues running for at least 15 seconds after the compressor has stopped.

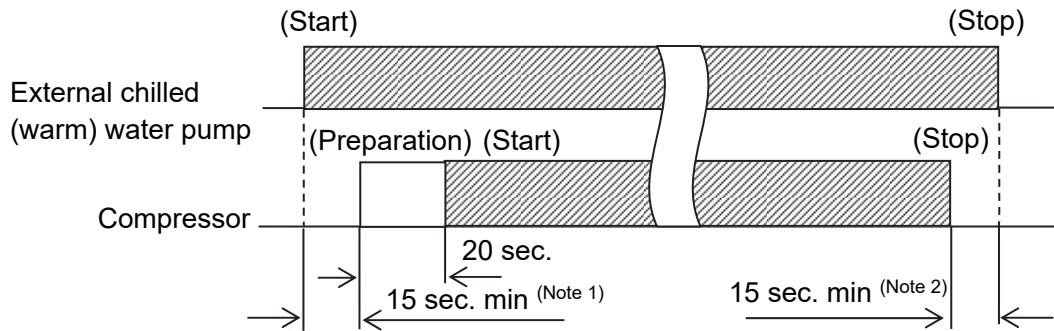

Note 1. The preceding operation of the external pump is automatically prolonged (to up to 180 seconds; field adjustable) until a water flow to a module stabilizes.

Note 2. The time that the external pump continues running after the compressor has stopped depends on the low-pressure states of each circuit. (up to 180 seconds; field adjustable)

To protect water from freezing, the external pump not only continues running for some time after the heat pump is stopped, but also is activated automatically while the heat pump is off according to the water and evaporation temperatures.

#### Note

When you use the pump group control, ensure that water is present in the pipe to protect the pump before you start it. Exercise care so that the water circuits must not be isolated by the solenoid valve, etc.

### 4. Single-module operation

The unit module mode is available to allow you check high-pressure switch during a test run or for use as an emergency backup in the event of a failure of the module controller.

In this mode, the module is activated when the entering water temperature exceeds the capacity control enable threshold and deactivated when it drops below the capacity control disable threshold.

Unless any other module is running in Remote Group mode, the internal pump operates at a frequency that results in a preprogrammed flow rate. If there are any modules running in Remote Group mode, the internal pump operates at variable speeds according to the average of the operation frequencies of the other modules.

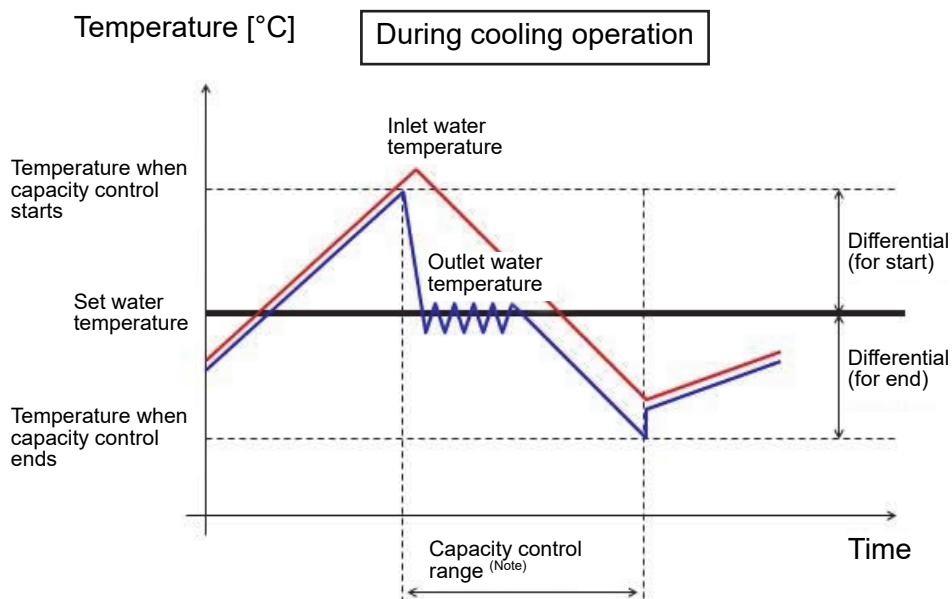

Note: The unit controller determines the number of compressors to run (out of the four compressors) and their operation frequencies in order to make the leaving water temperature close to the setpoint.

## 5. Fan control

DC motors control fans to make them turn at 100 to 900 rpm.

In Cooling mode, the fan speed is controlled in such a way that the condensing temperature will be equal to the setpoint according to the compressor frequency. In the Heating mode, the fan speed is controlled according to the compressor frequency and the outdoor air temperature.

## 6. Factory defaults

### (a) Time guards

Event	During group control from module controller	During individual module operation
Compressor minimum running time	180 seconds	
Compressor minimum stop time	120 seconds	
Circuit increase interval (minimum)	60 seconds	
Circuit decrease interval (minimum)	30 seconds	
Fan pre-operation time	20 seconds	
Internal pump pre-operation (minimum)	15 seconds	
Internal pump remaining operation (minimum)	15 seconds	

Note 1: The time guards shown above are provided to prevent frequent starting and stopping of the compressor. The compressor operation will start after the internal pump pre-operation time and the fan pre-operation time have elapsed.

### (b) Module controller

Item	Unit	Factory setting	Variable range	Variable step
Cooling setting outlet temperature	°C	7	4 to 30	0.1
Heating setting outlet temperature	°C	45	25 to 55	0.1
Percentage of module faults for major faults	%	100	0 to 100	1
Demand current	A	0	0 to 5000	1

### (c) Unit controller

Item	Unit	Factory setting	Variable range	Variable step
Cooling setting outlet temperature	°C	7	4 to 30	0.1
Heating setting outlet temperature	°C	45	25 to 55	0.1
Minimum defrosting interval	Minutes	20	20 to 90	1
Maximum defrosting time	Minutes	10	5 to 12	1
Minimum oil return operation interval (during heating operation)	Minutes	240	180 to 300	10
Pump operation frequency	Hz	35	24 to 60	1

# 7. Unit start-up/stop flowchart

## (1) Models with an internal inverter pump

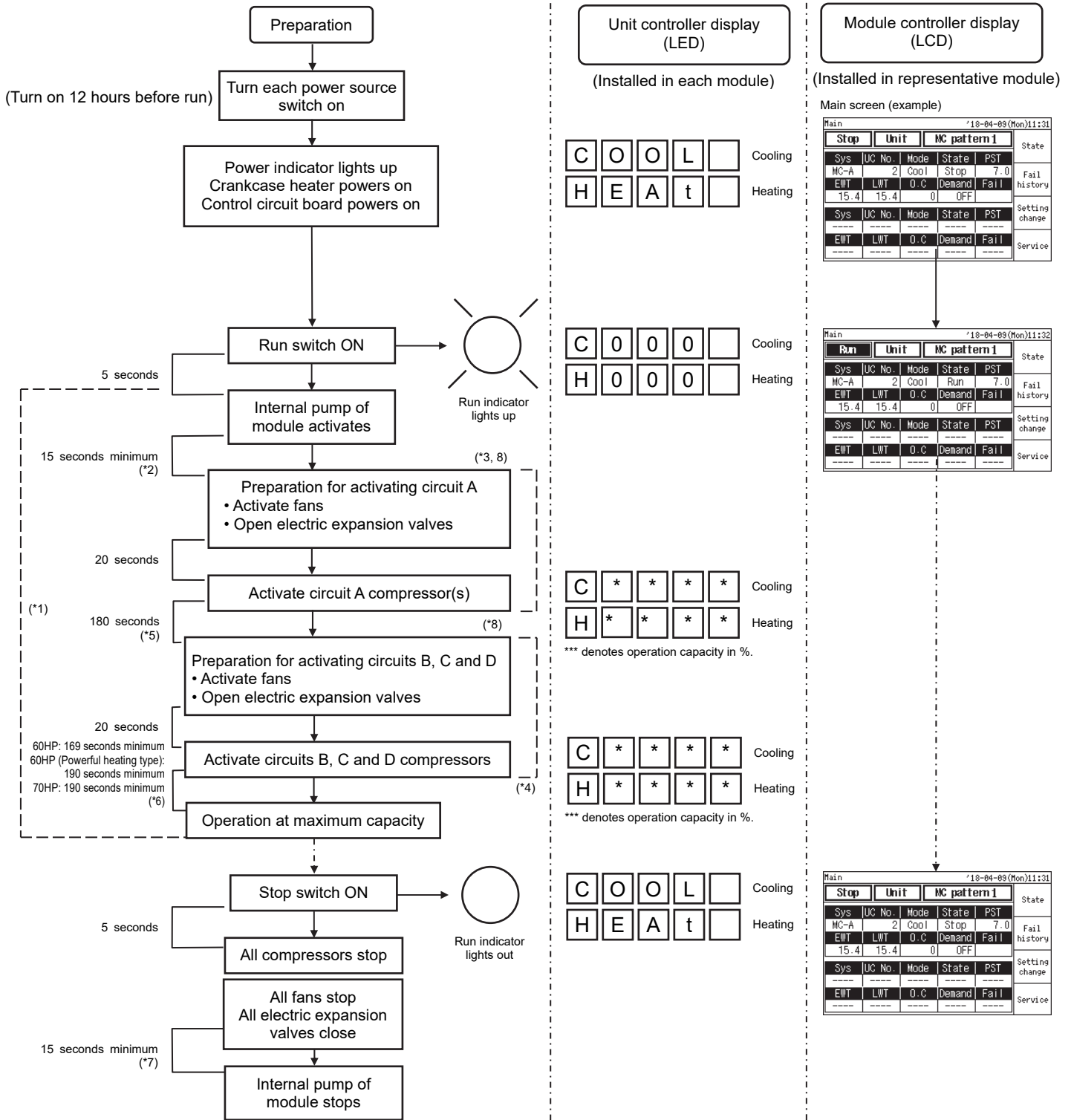

- (\*1) The number of modules to be operated simultaneously is determined according to the required flow rate on the load side. (When the required flow rate is large, all modules start at the same time.)
- (\*2) The internal pump pre-operation time is prolonged automatically until the flow volume to each module stabilizes.
- (\*3) The circuit with the shortest compressor runtime is activated first. (In the above example, the compressor runtime for circuit A is the shortest.)
- (\*4) The number of simultaneously activated circuits depends on the leaving water temp. of each module. (If the leaving water temp. is much higher than the setpoint, other circuits are activated at the same time.)
- (\*5) For continually high-load applications such as computer cooling, the pump may be customized to shorten this period. (For details, contact Toshiba Carrier.)
- (\*6) Minimum periods taken for compressors to reach the maximum operation frequency after start-up (May be longer depending on leaving water temperature.)
- (\*7) The remaining operation time of the internal pump depends on the low-pressure states of each circuit (up to 180 seconds).
- (\*8) The operating capacity may be suppressed due to conditions at the time of activation, and the time required to reach the maximum operating capacity may become long. Furthermore, when the heating operation is performed, the fans may be stopped to protect the compressor and activation may occur under the condition of the expansion valves being closed.



## (2) Pumpless models

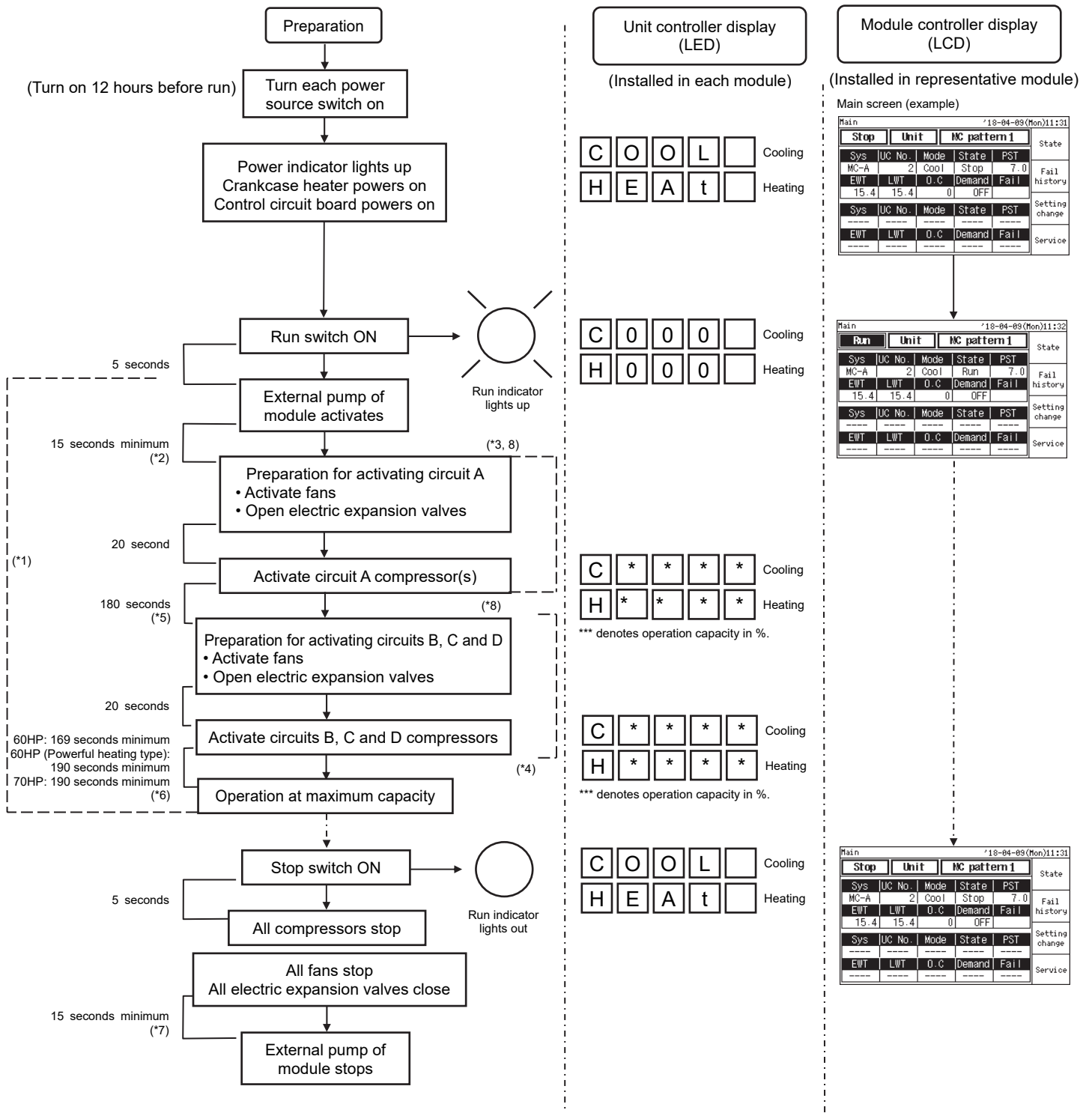

(\*1) All modules are activated simultaneously.

(\*2) The external pump pre-operation time is prolonged automatically until the flow volume to each module stabilizes. (Up to 180 seconds; field adjustable)

(\*3) The circuit with the shortest compressor runtime is activated first. (In the above example, the compressor runtime for circuit A is the shortest.)

(\*4) The number of simultaneously activated circuits depends on the leaving water temp. of each module. (If the leaving water temp. is much lower than the setpoint, other circuits are activated at the same time.)

(\*5) For continually high-load applications such as computer cooling, the pump may be customized to shorten this period. (For details, contact Toshiba Carrier.)

(\*6) Minimum periods taken for compressors to reach the maximum operation frequency after start-up (May be longer depending on leaving water temperature.)

(\*7) The remaining operation time of the external pump depends on the low-pressure states of each circuit (180 seconds maximum; field adjustable).

(\*8) The operating capacity may be suppressed due to conditions at the time of activation, and the time required to reach the maximum operating capacity may become long. Furthermore, when the heating operation is performed, the fans may be stopped to protect the compressor and activation may occur under the condition of the expansion valves being closed.

## 8. Demand control

Demand control is possible by applying a no-voltage a-contact continuous signal to the module controller. Demand control can be applied to "Electric current: A", "Capacity: %", "Rated power ratio: %", "Power consumption ratio: %", or "Power: kW". Demand control limits the total of all modules in the system to no greater than the demand control value programmed in the module controller. This limit is programmable between the following values. Refer to "6-1 Heat pump control wiring diagram" when inputting to the module controller. It can be set in 3 stages as shown in the table below.

Digital input	Demand OFF	Demand 1	Demand 2	Demand 3
Demand input 1	OFF	ON	OFF	ON
Demand input 2	OFF	OFF	ON	ON

(Note) With the initial settings of digital input items, only "Demand input 1" is valid. When using "Demand input 2", set the digital input item to "Demand input 2" and then set the corresponding input port.

Items to which demand control can be applied	Unit	Function	Settable range
Electric current (A)	A	Limits the total of all modules in the system so that the set electric current value is not exceeded.	0 to 5000
Capacity (L)	%	Limits the electric current value in the system so that the capacity value is not exceeded when the reference electric current value is 100%.	0 to 100
Rated power ratio (R)	%	Limits the electric current value in the system so that the rated power ratio is not exceeded when the reference electric current value is 100%.	0 to 100
Power consumption ratio (C)	%	Limits the power value in the system so that the power consumption ratio is not exceeded when the power consumption at demand input is 100%.	0 to 100
Electric power (W)	kW	Limits the total power value of all modules in the system so that the set power value is not exceeded.	0 to 5000

## 9. Auto recovery from power failures (customization)

When the Run/Stop input is a pulse signal, the unit can be customized to support auto recovery from power failures. (When a Continuous signal is used, this custom option is not available since the unit keeps track of the ON/OFF state of the make signal.) Times from 2 sec. to 10 min. can be selected for auto recovery from power failure. For details, contact Toshiba Carrier.

### <If recovery from power failures does not support customization>

The operation of the heat pump and module controller at the time of a power failure is as follows, depending on the power failure time.

[Less than 20 msec → Power failure of duration within 20 msec is not considered as power failure and operation continues]

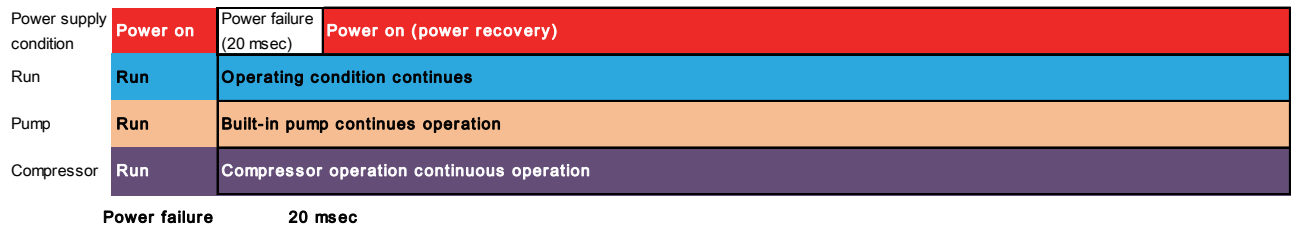

[Less than 50 msec → For power failure of duration between 20 msec and 50 msec, operation is temporarily stopped, but is automatically restored]

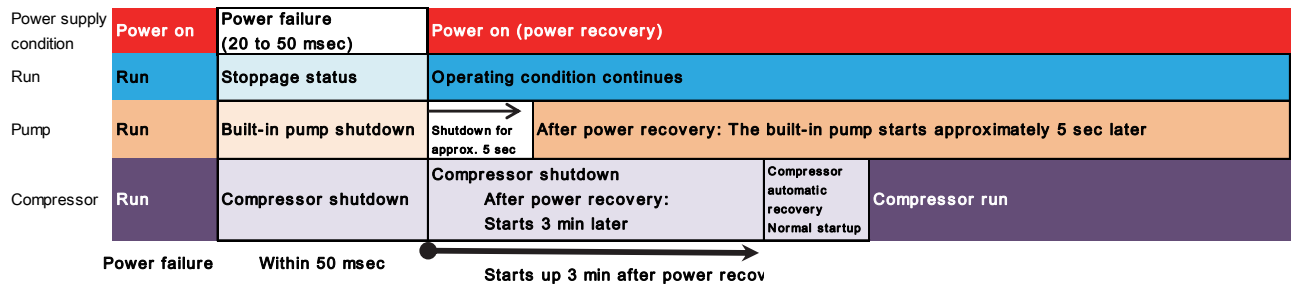

[50 msec or more → Power failure of duration 50 msec or more is considered a power failure and the equipment shuts down. Manual reset (external signal required)]

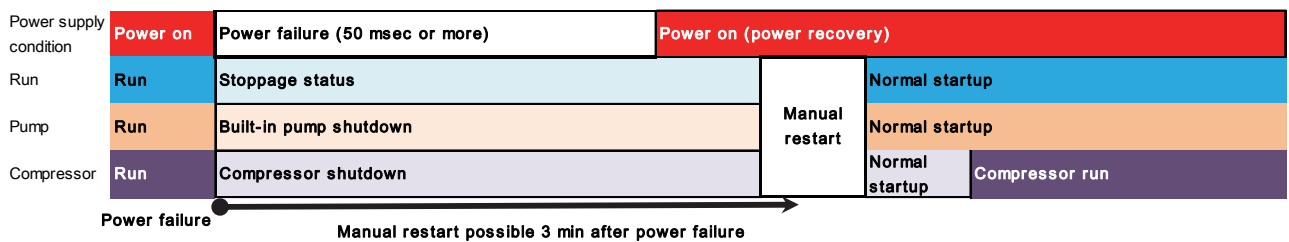

Note 1: The above times are approximate.

Note 2: Auto recovery of module controller from power failure is possible with customization. (In the Unit or External mode)

## 10. Protection control for risk distribution

The protection control feature of the module controller stops a module operation if it determines that the module cannot continue to operate any longer, based on the states of the protective devices and sensors. If a given circuit in a module has failed, another circuit in that module automatically initiates backup operation unless all the circuits in it fails. (Depending on protection control (see the error code list on the next page), the module controller stops all the circuits or only the failed circuit.) Additionally, in the event that a module has failed, another module can automatically initiate backup operation; in this case, however, since fewer modules are available for active operation, the maximum system performance is lowered. If the percentage of failed circuits (i.e., the ratio of failed circuits in a system<sup>\*1</sup> to the number of all circuits in a system<sup>\*2</sup>) has risen above the programmed threshold, the module controller displays and signals a major fault indication. This threshold is programmable with the module controller. If the percentage of failed circuits is greater than the threshold, the module controller indicates a major fault. If it is less than the threshold, the module controller indicates a minor fault. In both cases, one or more working modules are activated as a backup. The factory default for the threshold is 100%. Modify the percentage as necessary.

\*1 Failed circuits in a system include:

- Circuits that fail while running in the Remote mode
- Circuits that fail while running in the Unit mode
- Circuits of the modules that are idle in the Unit mode
- Circuits that are idle in the Unit and Remote modes

\*2 The number of all circuits in a system means:

In Cooling mode: Number of circuits of cooling-only and heat pump modules

In Heating mode: Number of circuits of heat pump and heat machine modules

### **(1) Major faults: When the percentage of failed circuits is greater than the threshold**

- The unit controller for the failed module shows a module error code on the LED display.
- The LCD monitor of the module controller shows the failed module no. and circuit name(s), and an error code. The module controller also provides major-fault signalling.
- In the event of a major fault, the module controller activates a normal module(s) in the system as a backup.
- If the number of the failed circuits in a system has fallen below the threshold as a result of a fault reset by the unit controller, the major fault status is reset and changed to a minor fault.

### **(2) Minor faults: When the percentage of failed circuits is less than the threshold**

- The unit controller for the failed module shows a module error code on the LED display.
- The LCD monitor of the module controller shows the failed module no. and circuit name(s), and an error code. The module controller also provides minor-fault signalling.
- In the event of a minor fault, the module controller activates a normal module(s) in the system as a backup.
- If all the failed circuits in a system have been reset as a result of a fault reset by the unit controller, the minor fault status is reset.

In the event of a module failure, the LCD monitor of the module controller and the LED display on the unit controller of the failed module show an error code.

## **[Resetting a fault]**

### **(a) Resetting all the circuits of a module using a unit controller**

To reset a fault, touch STOP on the operation panel located inside the power box of a module. Upon fault reset, the Remote/Unit switch is automatically set to Unit module. After you fix the cause of the fault, set it back to Remote Group.

### **(b) Resetting a fault using the module controller**

If the operating mode is External or Remote, a stop signal from an external device (e.g., a central supervisory board) or a remote device (i.e., optional group controller) cannot be used to reset a fault. Use the LCD screen of the module controller to turn off the associated modules, which resets the faults. In this case, a fault reset is performed for all modules connected to the module controller. Upon fault reset, the operating mode is automatically set to Unit. After you fix the cause of the fault, set it back to External or Remote.

\* A custom option is available for supporting a fault reset using an external or remote stop signal.

For details, contact Toshiba Carrier.

### **(c) Resetting a fault using the optional group controller**

If the current operating mode is External or Remote, a stop signal from an external device (e.g., a central supervisory board) or a remote device (i.e., custom Web monitor) cannot be used to reset a fault. Use the LCD screen of the group controller to turn off the associated modules, which causes the faults of all the connected module controllers and unit controllers to be reset. Upon fault reset, the operating mode is automatically set to Unit. After you fix the cause the fault, set it back to External.

\* A custom option is available for supporting a fault reset using an external or remote stop signal.

For details, contact Toshiba Carrier

## 11. List of error codes

In the event of a fault, the error log of the module controller and the LED display on unit controller provide a description of the fault. The LED display on the operation panel (unit controller) shows the fault code and the name of the fault-causing circuit. The module controller shows the date and time when the fault occurred, the failed module and circuit names, error code and its description.

In the event of a fault, the circuit name appears in the LED display on the unit controller operation panel. The digit "0" in the circuit name position denotes the entire module; the letter "A" denotes Circuit A, the lowercase "b" denotes Circuit B, the letter "C" denotes Circuit C, and the lowercase "d" denotes Circuit D. The letters "C" and "A" also signify a failure of the upstream unit (Circuits C and D) and the downstream unit (Circuits A and B) respectively.

Error code (Hexadecimal)	Item	Description	Circuit name displayed	Stop process
00	Normal	Normal	0	None
03	Phase loss error	Power phase loss is detected.	0	Applicable circuit
04	Output voltage error	EEV blown fuse	0	Applicable circuit only
05	Pump inverter overcurrent protection operation (Note 1)	If pump inverter detects overcurrent	0	Applicable module
06	Pump inverter overvoltage protection operation (Note 1)	If pump inverter detects overvoltage	0	Applicable module
07	Pump inverter overload protection operation (Note 1)	If pump inverter detects overload	0	Applicable module
08	Pump inverter overheat protection operation (Note 1)	If pump inverter detects overheat at heat sink	0	Applicable module
0A	Pump inverter motor overload protection operation (Note 1)	If pump inverter detects motor overload	0	Applicable module
0C	Pump inverter low voltage protection operation (Note 1)	If pump inverter detects low voltage	0	Applicable module
0D	Pump inverter output loss of phase protection operation (Note 1)	If pump inverter detects output loss of phase	0	Applicable module
0E	Pump inverter other protection operation (Note 1)	If pump inverter detects error other than those listed above	0	Applicable module
0F	Pump inverter communication error (Note 1)	If the inverter does not respond to communication from the CPU board	0	Applicable module
10	Module controller, unit controller communication error	Control board communication error (between module controller and unit controller)	0	Note 2
12	Internal communication fault	If EEV does not respond to communication from the CPU board	A,C	Applicable module
1A	HIF board communication error	Data cannot be received between CPU board and HIF board	0	Operation continues only in the case of error output
1B	IO board communication error	If IO board does not respond to communication from the CPU board	0	Applicable module
20(Note3)	Thermistor error (chilled (warm) water entering temperature)	Disconnection, shorting, or loose connection of applicable thermistor	C	Only two circuits on the upstream side
21(Note3)	Thermistor error (chilled (warm) water leaving temperature)	Disconnection, shorting, or loose connection of applicable thermistor	A	Only two circuits on the downstream side
22(Note3)	Thermistor error (chilled (warm) water middle temperature)	Disconnection, shorting, or loose connection of applicable thermistor	C	Only two circuits on the upstream side
2E	Relative humidity sensor error (Note 4)	Disconnection, shorting, or loose connection of applicable thermistor	0	Operation continues only in the case of error output
2F	Thermistor error (outside air temperature)	Disconnection, shorting, or loose connection of applicable thermistor	0	* Acquire outside air temperature from another module and continue operation of the applicable module. * If the temperature cannot be acquired from another module, stop the applicable module.
30	Thermistor error (compressor discharge gas temperature)	Disconnection, shorting, or loose connection of applicable thermistor	Name of applicable circuit	Applicable circuit only
31	Thermistor error (compressor suction gas temperature)	Disconnection, shorting, or loose connection of applicable thermistor	Name of applicable circuit	Applicable circuit only
32	Thermistor error (coil gas temperature 1) (Note 5)	Disconnection, shorting, or loose connection of applicable thermistor	Name of applicable circuit	Applicable circuit only
33	Thermistor error (coil gas temperature 2) (Note 5)	Disconnection, shorting, or loose connection of applicable thermistor	Name of applicable circuit	Applicable circuit only
35	Thermistor error (reactor temperature)	Disconnection, shorting, or loose connection of applicable thermistor	Name of applicable circuit	Applicable circuit only Operation continues and only error output is performed.
40	High-pressure sensor error	Disconnection, shorting, or loose connection of the applicable sensor	Name of applicable circuit	Applicable circuit only
41	Low-pressure sensor error	Disconnection, shorting, or loose connection of the applicable sensor	Name of applicable circuit	Applicable circuit only
4A	Water inlet pressure sensor error	Disconnection, shorting, or loose connection of the applicable sensor	0	Applicable module
4B	Water outlet pressure sensor error	Disconnection, shorting, or loose connection of the applicable sensor	0	Applicable module
4C	Pump suction press sensor err	Disconnection, shorting, or loose connection of the applicable sensor	0	Operation continues only in the case of error output
50 (Note 7)	Freeze prevention operation triggered	Chilled/warm water outlet temperature is 2°C or less.	Name of applicable circuit	Only the two circuits connected to the applicable heat exchanger
51	High temperature prevention operation triggered	Chilled/warm water outlet temperature is 60°C or more.	Name of applicable circuit	Only the two circuits connected to the applicable heat exchanger
52(Note7)	Low flow rate protection operation triggered	Flow rate of applicable module is 100 L/min or less.	0	Applicable module
53	Water temperature inlet/outlet reversal	Water temperature reversal in inlet and outlet, with a difference of 2°C or more sustained for one minute	0	Applicable module
5A	Subnormal pump suction press	Continue for 1 minute with pump suction pressure of less than -40 kPa during pump operation	0	Applicable module
5B	Chilled (warm) water pressure rise protection operation	Chilled (warm) water inlet pressure is 1 MPa or more.	0	Applicable module
60	High pressure cut	High-pressure switch (4.15MPa) is triggered.	Name of applicable circuit	Applicable circuit only

Error code (Hexadecimal)	Item	Description	Circuit name displayed	Stop process
61(Note3)	Low pressure error 1 (Note 6)	During operation, low pressure of 0.45 MPa or less is sustained for one minute, or low pressure is 0.12 MPa or less	Name of applicable circuit	Applicable circuit only
62(Note3)	Low pressure error 2 (Note 6)	During operation, the state of evaporation temperature of -6°C or lower (changes depending on chilled/warm water outlet water temperature) continues for 30 seconds after the lapse of a certain time from the start of the compressor	Name of applicable circuit	Applicable circuit only
63	Compressor discharge gas overheat protection operation	Compressor discharge gas temperature at 120°C or more	Name of applicable circuit	Applicable circuit only
64(Note3)	Compressor suction gas temperature protection operation	During cooling operation, one minute after compressor starts and compressor suction gas temperature is -5°C or less	Name of applicable circuit	Applicable circuit only
65	Insufficient refrigerant error	Condensation pressure is 0.17 MPa or less	Name of applicable circuit	Applicable circuit only
66	Compressor operation out of range error	If condensation pressure or evaporation pressure is outside the operating range of the compressor continuously for 30 seconds (fluctuates depending on the condition)	Name of applicable circuit	Applicable circuit only
67	Compressor unstarted failure	Detects compressor malfunction	Name of applicable circuit	Applicable circuit only
71	Expansion valve 1 error	Expansion valve 1 is fully close and suction gas super heat is less than 3.0°C continuously for 10 minutes.	Name of applicable circuit	Applicable circuit only
72	Expansion valve 2 error	Expansion valve 2 is fully close and suction gas super heat is less than 3.0°C continuously for 10 minutes.	Name of applicable circuit	Applicable circuit only
73	Four-way valve error (Note 5)	Error in relationship of magnitude relation among discharge gas temperature, suction gas temperature and coil gas temperature continues for 5 minutes.	Name of applicable circuit	Applicable circuit only
74	Equalizer valve error	If there is a difference between the high pressure and the low pressure after the compressor stops	Name of applicable circuit	Applicable circuit only
75	Refrig injection line failure	Detects abnormalities in the injection 2-way valve or injection expansion valve	Name of applicable circuit	Applicable circuit only
7A	Cooling fan error	(1) Heat sink temperature is 95°C or higher, or reactor temperature is 130°C or higher (2) Heat sink temperature is 90°C or higher, or the reactor temperature is 110°C or higher, with the current limit being less than 50% of the maximum current. Error occurs.	Name of applicable circuit	Applicable module
A0	Compressor PWM IGBT short circuit error	Compressor PWM detects short circuit of IGBT	Name of applicable circuit	Applicable circuit only
A1	Compressor PWM position detection circuit error	Compressor PWM detects CT error.	Name of applicable circuit	Applicable circuit only
A2	Compressor PWM current sensor error	Compressor PWM detects CT error.	Name of applicable circuit	Applicable circuit only
A3	Compressor PWM compressor lock error	Compressor PWM detects compressor lock	Name of applicable circuit	Applicable circuit only
A4	Compressor PWM compressor breakdown error	Compressor PWM detects compressor motor current error.	Name of applicable circuit	Applicable circuit only
A5	Compressor PWM compressor system error	While compressor PWM is being powered, rotor is detected to have stopped.	Name of applicable circuit	Applicable circuit only
AC	Compressor PWM heat sink overheating error	Compressor PWM detects that the heat sink temperature is 110 °C or higher.	Name of applicable circuit	Applicable circuit only
AD	Compressor PWM temperature sensor short circuit error	Compressor PWM detects heat sink sensor short circuit.	Name of applicable circuit	Applicable circuit only
AF	Compressor PWM communication error	There is no response from PWM to EEV for more than 6 seconds.	Name of applicable circuit	Applicable circuit only
B0	Compressor PWM voltage error	Compressor PWM detects DC voltage error.	Name of applicable circuit	Applicable circuit only
B1	Compressor PWM board error	Compressor PWM board error is detected.	Name of applicable circuit	Applicable circuit only
C2	Fan inverter overload error	Fan inverter detects overload.	Name of applicable circuit	Applicable circuit only
C4	Fan inverter breakdown error	Fan inverter detects fan motor current error.	Name of applicable circuit	Applicable circuit only
C5	Fan inverter synchronization error	Fan inverter detects fan speed error.	Name of applicable circuit	Applicable circuit only
C6	Fan inverter board error	Fan inverter board error is detected.	Name of applicable circuit	Applicable circuit only
CC	Fan inverter heat sink overheat error	Fan inverter detects heat sink temperature error.	Name of applicable circuit	Applicable circuit only
CD	Fan inverter phase loss error	Fan inverter detects power phase loss.	Name of applicable circuit	Applicable circuit only
CE	Fan inverter voltage error	Fan inverter detects DC voltage error.	Name of applicable circuit	Applicable circuit only
CF	Fan inverter communication error	There is no response from CPU board to fan inverter for more than 6 seconds.	Name of applicable circuit	Applicable circuit only
F0	Compressor PWM converter protection operation	Compressor PWM detects converter error.	Name of applicable circuit	Applicable circuit only Changes depending on the setting
F1	DIPSW setting error	Difference between the voltage setting SW5-8 and the actual voltage is detected.	0	Applicable module Changes depending on the setting

Note 1: Only models with an internal inverter pump provide protection against pump inverter errors.

Note 2: If communication continuously fails for two minutes, only the applicable module stops. The module recovers automatically when communication returns to normal.

Note 3: If the EEV 1 control board fails, the A and B circuits stop, and if the EEV 2 control board fails, the C and D circuits stop.

Note 4: Relative humidity sensor abnormality is limited to 60HP (Powerful heating type) MC built-in module only.

Note 5: For thermistor abnormalities (coil temperature) and four-way valve problems, protection control is provided for the heat pump module only. Protection control is not provided to the cooling-only module.

Note 6: "Low pressure error 1" is triggered within five minutes after the compressor start-up. In other cases, "Underpressure 2" applies.

Note 7: For a description of the causes of errors and their solutions, see "13. Operational Guidelines" in this material.

Note 8: For a list of MC error codes, see "13. Operational Guidelines" in this material.

# Refrigerant piping drawings

## 1. Heat pump

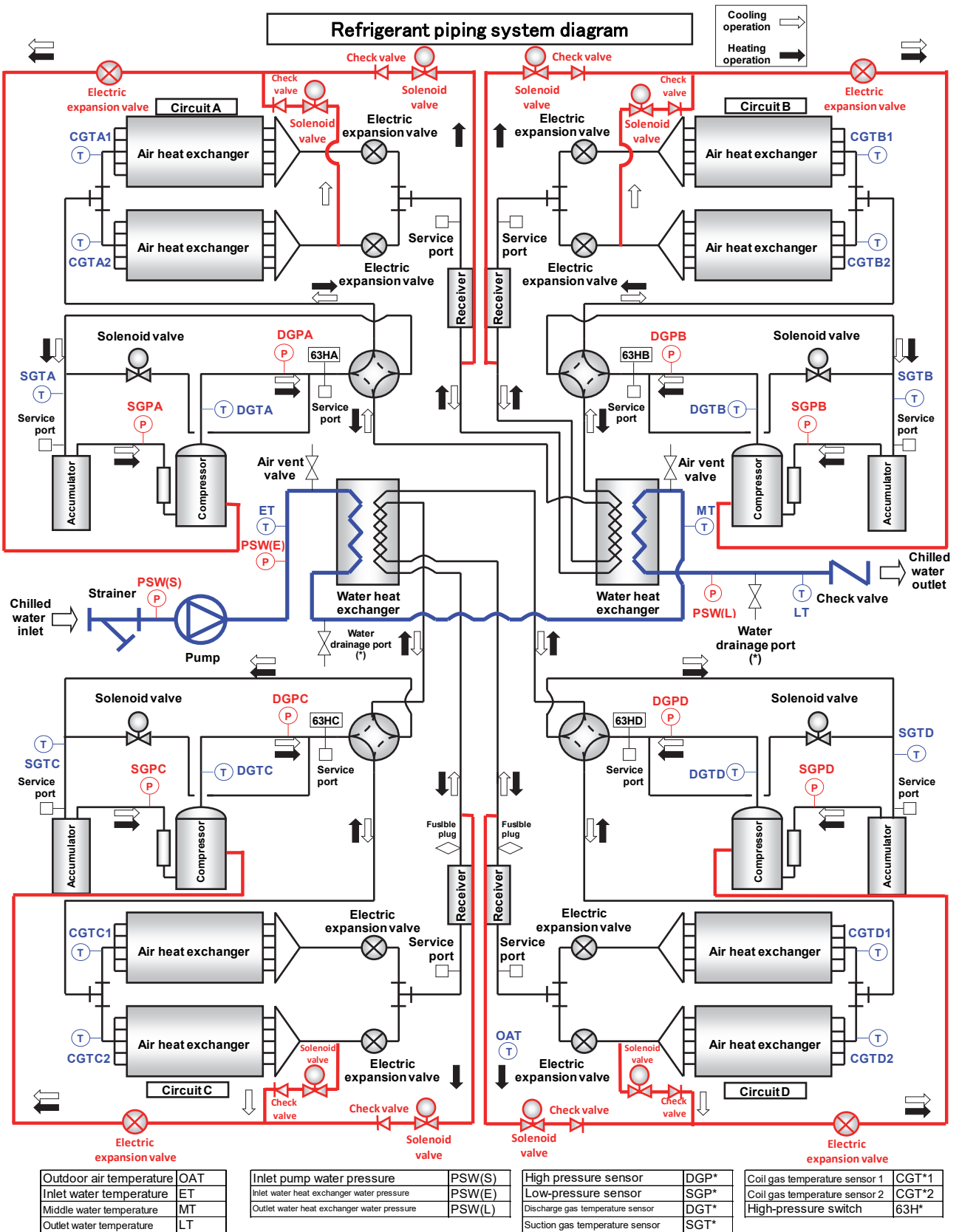

(Note 1) The above figure is a refrigerant piping system diagram for inverter pump-integrated machine.

The piping system of pumpless models lacks of the pump and check valve seen in this diagram.



2. Cooling only

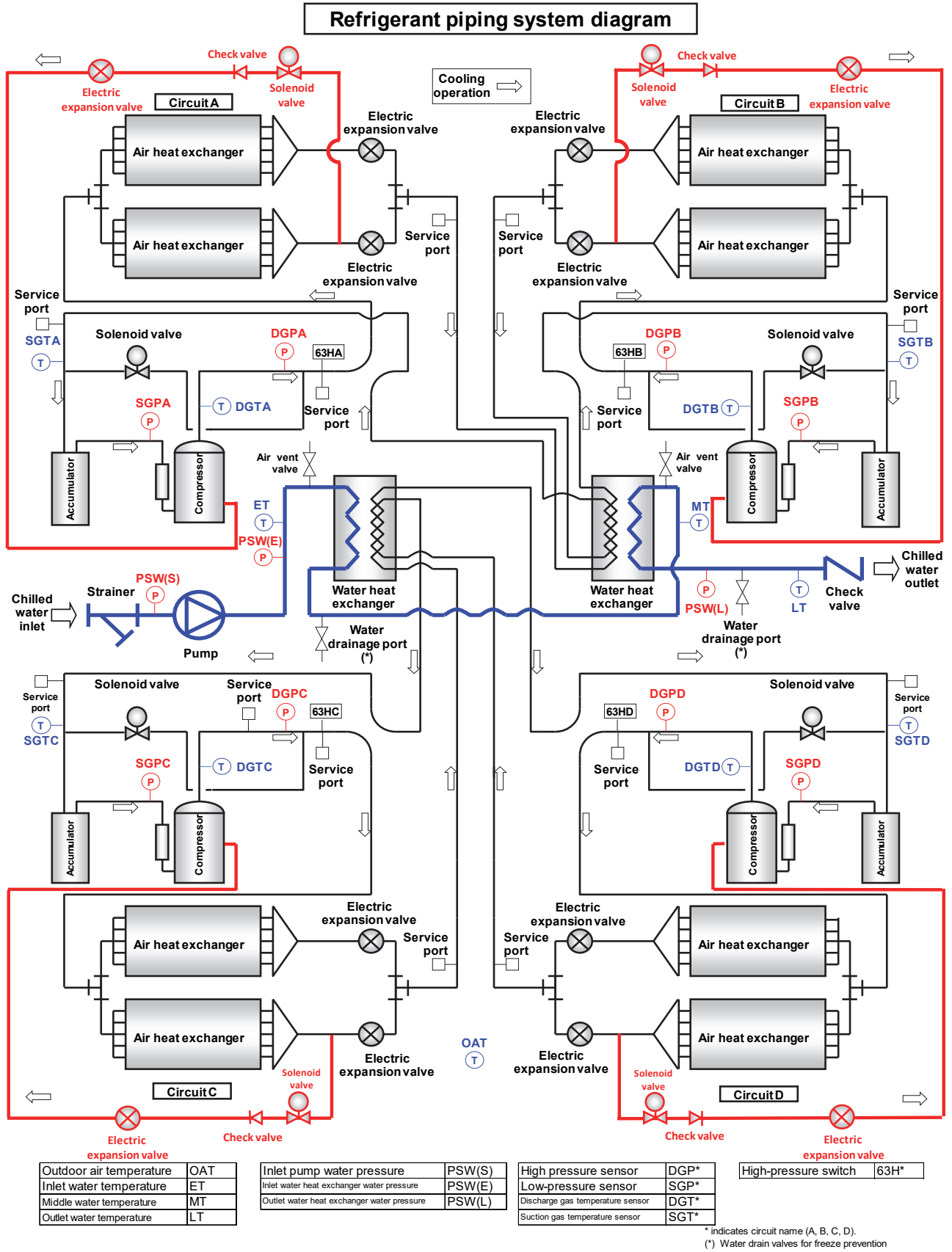

(Note 1) The above figure is a refrigerant piping system diagram for inverter pump-integrated machine.  
The piping system of pumpless models lacks of the pump and check valve seen in this diagram.

# Operating Standard and Operating Range

Follow the usage standards below.

Item		Description				
Power	Voltage fluctuation	Within $\pm 10\%$				
	Phase balance	Within $\pm 2\%$ (maximum voltage - average voltage) / average voltage x 100				
	Frequency fluctuations	Within $\pm 2\%$				
Chilled (warm) water	Water pressure	<table border="1"> <tr> <td>Model with integrated inverter pump</td> <td>0.7 MPa or less</td> </tr> <tr> <td>Pumpless model</td> <td>0.98 MPa or less</td> </tr> </table>	Model with integrated inverter pump	0.7 MPa or less	Pumpless model	0.98 MPa or less
	Model with integrated inverter pump	0.7 MPa or less				
Pumpless model	0.98 MPa or less					
Water quality	<ul style="list-style-type: none"> <li>- Follow Japan Refrigeration and Air Conditioning Industry Association's "Water Quality Guidelines for Cooling and Air Conditioning Devices" (JRA-GL-02-1994).</li> <li>- Must not include dissolved materials that harm copper, iron, or brazing material.</li> </ul>					
Water spray	Water pressure	0.2 MPa or less				
	Water quality	<ul style="list-style-type: none"> <li>- Follow Japan Refrigeration and Air Conditioning Industry Association's "Water Quality Guidelines for Cooling and Air Conditioning Devices" (JRA-GL-02-1994).</li> <li>- Prepare a 50 mesh or more strainer in the supply water pipe.</li> <li>- Carry out water quality treatment with water softeners as necessary.</li> </ul>				
Installation location		<ul style="list-style-type: none"> <li>- USX EDGE modules must be installed outside.</li> <li>- Ensure space is secured for servicing and the intake of fresh air (exhaust air from the heat pump fans must not short circuit).</li> <li>- Not a depression or a location with poor ventilation.</li> <li>- The location must be able to properly support the operating weight of the heat pump.</li> <li>- Ensure drainage is installed to provide water removal from the water spray system and condensation water from the each module. (Dispose of drainage and waste water from the heat pump as necessary.)</li> <li>- Prepare measures for accumulating snow and strong winds, as necessary.</li> <li>- Prepare measures to prevent damage from salt (Specifications for salt resistance and heavy salt resistance are available as options for USX EDGE).</li> <li>- Location must not be over 1/2000 inclination.</li> </ul>				
Surrounding environment		<ul style="list-style-type: none"> <li>- Do not install in locations where there is excessive machine oil in the air.</li> <li>- Do not install in locations where sulphide gas is present in the air (such as hot spring locations).</li> <li>- Do not install in locations where there is a risk of the generation, inflow, or accumulation of flammable gas.</li> <li>- Do not install in locations where the atmosphere is acidic or alkaline.</li> <li>- Do not install in locations where there are airborne carbon fibres or metal particles.</li> <li>- Do not install in other locations that are exposed to the smoke from smokestacks.</li> <li>- Not a location with high humidity</li> <li>- Not a location with poor ventilation or where short circuits occur.</li> </ul>				

Use the equipment within the operating range below. (Note1)

Model		50HP, 60HP	50HP (Powerful heating type), 60HP (Powerful heating type)	70HP
Power voltage		Within ±10% of rated voltage		
Flow rate range <sup>(Note 2)</sup>	L/min	150 to 600	150 to 600	150 to 650
Outlet water temperature <sup>(Note 3)</sup>	°C	Cooling	4 to 30	
		Heating <sup>(Note 7)</sup>	25 to 55	
		Inlet/outlet temperature difference	5 to 10	
Outdoor air temperature <sup>(Note 4)</sup>	°C	Cooling	-15 to 52DB	
		Heating <sup>(Note 7)</sup>	-15 to 43DB, 32WB	-20 to 43DB, 32WB
In-system minimum holding water volume <sup>(Note 6)</sup>	L	50HP: 717 (1075) 60HP: 860 (1290)		956 (1434)
In-unit holding water volume	L	36		

Note 1: The specifications shown in the table above are for one module.

Note 2: Ensure that the rated flow rate per module is within the above flow rate range. The flow rate changes automatically according to the load fluctuation by the internal inverter pump.

Note 3: When the heat pump starts, it can be used within the following range within 1 hour only. However, during this time, the required inlet/outlet temperature difference may not be achieved.  
 Cooling: Chilled water inlet 45°C or less, Cold water outlet 35°C or less  
 Heating: Hot water inlet 10°C or more, Hot water outlet 20°C or more  
 In addition, if the operating range will exceed 1 hour, install a bypass in the water piping system if necessary so that the operation does not exceed the operating range shown in the table above.

Note 4: The warm water outlet temperature is limited by outside air temperature conditions as shown below.

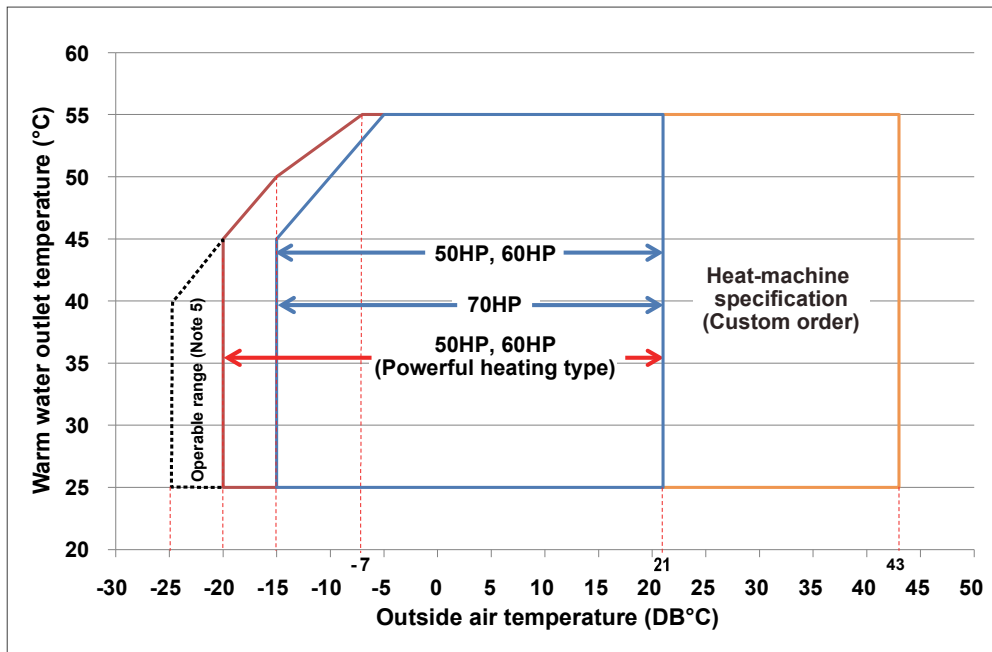

Note 5: System performance is not guaranteed between -20°C and -25°C outside air temperature. Please be aware that system performance can be effected by external factors (for example snow drifts, the surrounding environment etc.) even when the outside air temperature is inside the operating envelope shown above.

Note 6: When calculating holding water volume, calculate the smallest water volume for the piping flow passage, taking the bypass channel and other factors into consideration. The holding water volumes shown in the table are values for a designed outlet/inlet temperature differential of  $\Delta T = 7^\circ\text{C}$  and for the values in (parentheses) a designed outlet/inlet temperature differential of  $\Delta T = 5^\circ\text{C}$ . Use straight line interpolation to calculate any other designed outlet/inlet temperature differentials.

Note 7: Heat pump only.

■ Large temperature difference specification (Customized Option) <sup>(Note1)</sup>

\* Water outlet/inlet temperature difference: 10°C to 16°C

Item	Model	50HP, 60HP	50HP (Powerful heating type), 60HP (Powerful heating type)	70HP
Power voltage		Within ±10% of rated voltage		
Flow rate range <sup>(Note 2)</sup>	L/min	150 to 300	150 to 300	150 to 325
Outlet water temperature <sup>(Note 3)</sup>	°C	Cooling	4 to 30	
		Heating <sup>(Note 7)</sup>	25 to 55	
		Inlet/outlet temperature difference	10 to 16	
Outdoor air temperature <sup>(Note 4)</sup>	°C	Cooling	-15 to 52DB <sup>(Note 8)</sup>	
		Heating <sup>(Note 7)</sup>	-15 to 43DB, 32WB	-20 to 43DB, 32WB
In-system minimum holding water volume <sup>(Note 6)</sup>	L	50HP: 478 (287) 60HP: 573 (344)		637 (382)
		In-unit holding water volume		
	L	36		

Note 1: The specifications shown in the table are for one module.

Note 2: Make sure to decide a rated flow rate per module within this flow rate range. The flow rate changes automatically according to the load fluctuation by the internal inverter pump.

Note 3: When the heat pump starts, it can be used within the following range within 1 hour only. However, during this time, the required inlet/outlet temperature difference may not be achieved.  
Cooling: Chilled water inlet 45°C or less, Cold water outlet 35°C or less  
Heating: Hot water inlet 10°C or more, Hot water outlet 20°C or more  
In addition, if the operating range will exceed 1 hour, install a bypass in the water piping system if necessary so that the operation does not exceed the operating range shown in the table above.

Note 4: The warm water outlet temperature is limited by outside air temperature conditions as shown below.

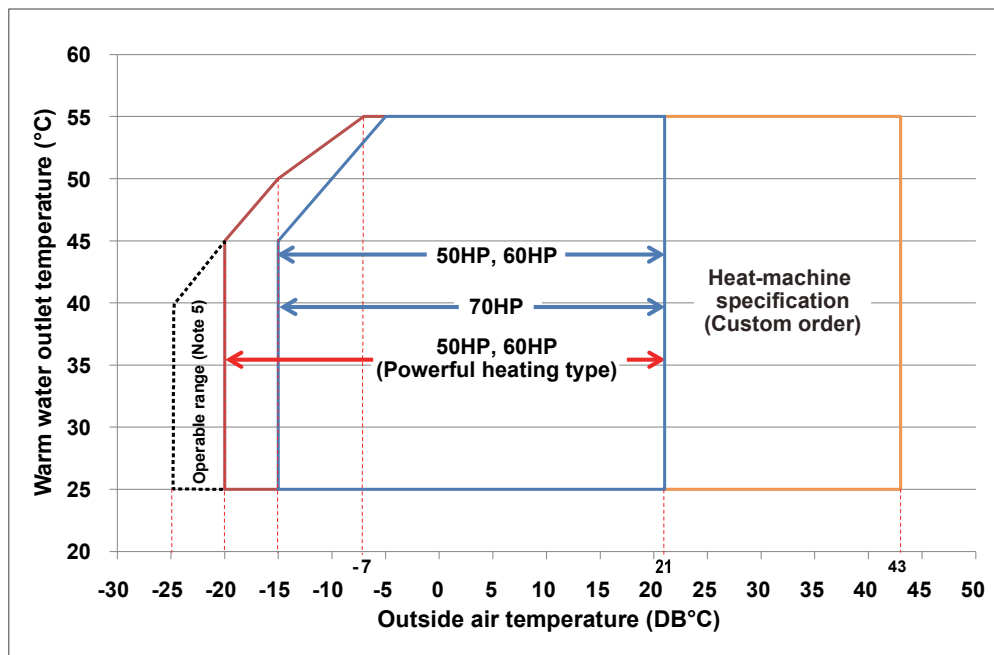

Note 5: Capability is not guaranteed at -20°C to -25°C. Due to the influence of the wind, snow, the surrounding environment, etc., the ability may not be demonstrated even in the temperature range of -20°C or higher (60HP (Powerful heating type) only).

Note 6: When calculating holding water volume, calculate the smallest water volume for the piping flow passage, taking the bypass channel and other factors into consideration. The holding water volumes shown in the table are values for a designed outlet/inlet temperature differential of  $\Delta T = 10^\circ\text{C}$  and for the values in (parentheses) a designed outlet/inlet temperature differential of  $\Delta T = 16^\circ\text{C}$ . Use straight line interpolation to calculate any other designed outlet/inlet temperature differentials.

Note 7: Heat pump only.

Note 8: Built in inverter pump model OAT range: -15°C to 46°C  
Pump-less model OAT range: -15°C to 43°C

# Component Rating

## Heat Pump

### Standard Specification

			50HP	50HP (Powerful heating type)	60HP	60HP (Powerful heating type)	70HP
Compressor Motor (kW)	with pump	Std.	9.0 × 4	9.0 × 4	11.2 × 4	12.5 × 4	13.3 × 4
		High-EER	9.0 × 4	9.0 × 4	11.1 × 4	12.5 × 4	12.5 × 4
	without pump	Std.	9.0 × 4	9.0 × 4	11.2 × 4	12.5 × 4	13.3 × 4
		High-EER	9.0 × 4	9.0 × 4	11.1 × 4	12.5 × 4	12.5 × 4
Fan Motor	(kW)		1.2 × 4				
Pump Motor	(kW)		1.5 (2P)				2.2 (2P)
High Pressure Switch	(MPa)	63H	4.15 (Open) / 3.25 (Close)				
Overcurrent Protection	(A)	A4 IPDU	19.0 × 4	19.0 × 4	22.3 × 4	24.2 × 4	26.8 × 4
Pump Motor Overload Protection			Microprocessor control				
Fan Motor Overload Protection			Microprocessor control				
Fan Cycling Type			Microprocessor control				
Dehumidification			Shunt Type - Reverse cycle type				
Disc. Gas Overheat Prevention Thermo	(°C)	UC CPU	≥ 120°C				
Suct. Gas Temperature (only at cooling)	(°C)	UC CPU	≤ Pure water -5.0°C				
Antifreeze Thermo	(°C)	UC CPU	≤ 2.0°C				
High Water Temp. Prevention Thermo	(°C)	UC CPU	≥ 60.0°C				
Low Pressure 1	(MPa)	UC CPU	Cooling: ≤ 0.45MPa continues 1 min. or more Heating: below 0.12 MPa			0 MPa (depend on OAT)	Cooling: ≤ 0.45 MPa continues 1 min. or more Heating: below 0.12 Mpa
Low Pressure 2 (only at cooling)	(MPa)	UC CPU	Low pressure ≤ 0.56 MPa continues more than 30 sec <sup>(note2)</sup>				
Low Water Flow Protection	(L/min)	UC CPU	≥ 150 (L/min)				
Water Pressure	(kPa)	UC CPU	≥ 1000 (kPa)				
Case Heater	(W)	CH	37 × 4				
Fuse (Control Circuit)	(A)	F1	16				
Transformer capacity	(VA)	Tr	600				
Transformer capacity	(VA)	Tr (MC)	50				
Fuse (Case Heater, Solenoid Valve)	(A)	EEV	6.3 × 2				
Fuse (Drain Pan Heater) <sup>(Note1)</sup>	(A)	F4,5	-	16	-	16	-
Fuse (Fan Fuse)	(A)	IO	3				
Fuse (For MC)	(A)	MC	1				
Fuse (Fan Motor)	(A)	F2,3	20 A				
Drain Pan Heater <sup>(Note1)</sup>	(W)	DH	-	75 × 6	-	75 × 6	-
SCCR	(A)		10 kA				

## Cooling-Only

### Standard Specification

			50HP	60HP	70HP
Compressor Motor (kW)	with pump	Std.	9.0 × 4	11.2 × 4	13.3 × 4
		High-EER	9.0 × 4	11.1 × 4	12.5 × 4
	without pump	Std.	9.0 × 4	11.2 × 4	13.3 × 4
		High-EER	9.0 × 4	11.1 × 4	12.5 × 4
Fan Motor	(kW)		1.2 × 4		
Pump Motor	(kW)		1.5 (2P)	2.2 (2P)	
High Pressure Switch	(MPa)	63H	4.15 (Open) / 3.25 (Close)		
Overcurrent Protection	(A)	A4 IPDU	19.0 × 4	22.3 × 4	26.8 × 4
Pump Motor Overload Protection			Microprocessor control		
Fan Motor Overload Protection			Microprocessor control		
Fan Cycling Type			Microprocessor control		
Disc. Gas Overheat Prevention Thermo	(°C)	UC CPU	≥ 120°C		
Suct. Gas Temperature (only at cooling)	(°C)	UC CPU	≤ Pure water -5.0°C		
Antifreeze Thermo	(°C)	UC CPU	≤ 2.0°C		
High Water Temp. Prevention Thermo	(°C)	UC CPU	≥ 60.0°C		
Low Pressure 1	(MPa)	UC CPU	≤ 0.45 MPa continues 1 min. or more		
Low Pressure 2 (only at cooling)	(MPa)	UC CPU	Low pressure ≤ 0.56 MPa continues more than 30 sec <sup>(note2)</sup>		
Low Water Flow Protection	(L/min)	UC CPU	≥ 150 (L/min)		
Water Pressure	(kPa)	UC CPU	≥ 1000 (kPa)		
Case Heater	(W)	CH	37 × 4		
Fuse (Control Circuit)	(A)	F1	16		
Transformer capacity	(VA)	Tr	600		
Transformer capacity	(VA)	Tr (MC)	50		
Fuse (Case Heater, Solenoid Valve)	(A)	EEV	6.3 × 2		
Fuse (Fan Motor)	(A)	F2,3	20 A		
Fuse (Fan Fuse)	(A)	IO	3		
Fuse (For MC)	(A)	MC	1		
SCCR	(A)		10 kA		

(note1) Powerful heating type only

(note2) Value is for one module unit.

(note3) The suction pressure value is determined and automatically changed based on the leaving water temperature.  
The timing values will also automatically change in correspondence with the evaporating temperature.

# High EER Type

A water spray system, that sprays water onto the air heat exchanger surface (evaporative condenser), is installed on the chiller for all high EER USX EDGE model codes. Water is sprayed onto the heat exchanger when operation start temperature and the compressor capacity is greater than preset values for these parameters. Operation start/end temperature and operation start/end capacity can be adjusted. Use UP or DOWN of the unit controller to select "C. dnSt" and then touch ENTER. Then the setting value of d-□□ (where □□ is DN code) can be changed. The dimensional drawing of air heat exchanger spray, main specifications, and DN code list are shown below.

\* Pumpsless units exclude pumps and check valves

## Dimensional drawing for high EER type

No.	NAME	JOINT
1	WATER INLET	2-1/2" FLANGE
2	WATER OUTLET	2-1/2" FLANGE
3	COIL DRAIN	PT1-1/2" EXTERNAL THREAD
4	AIR VENT VALVE	PT1-1/2" INTERNAL THREAD
5	STRAINER	CASING: Equivalent to FC250
6	CHECK VALVE	CASING: Equivalent to FC200
7	WATER PIPING (INLET)	JIS10K FLANGE PIPING Equivalent to SUA304
8	WATER PIPING (OUTLET)	JIS10K FLANGE PIPING Equivalent to SUA304
9	PUMP	CASING: FC200
10	WATER HEAT EXCHANGER	PLATE, JOINT Equivalent to SUA316 SOLDER PURE COPPER
11	HOUSING TYPE JOINT	GASKET *1 EPDM
12	WATER SUPPLY PORT FOR SPRAY	PT1/2" EXTERNAL

\*1 DESCRIPTION OF WETTED PART

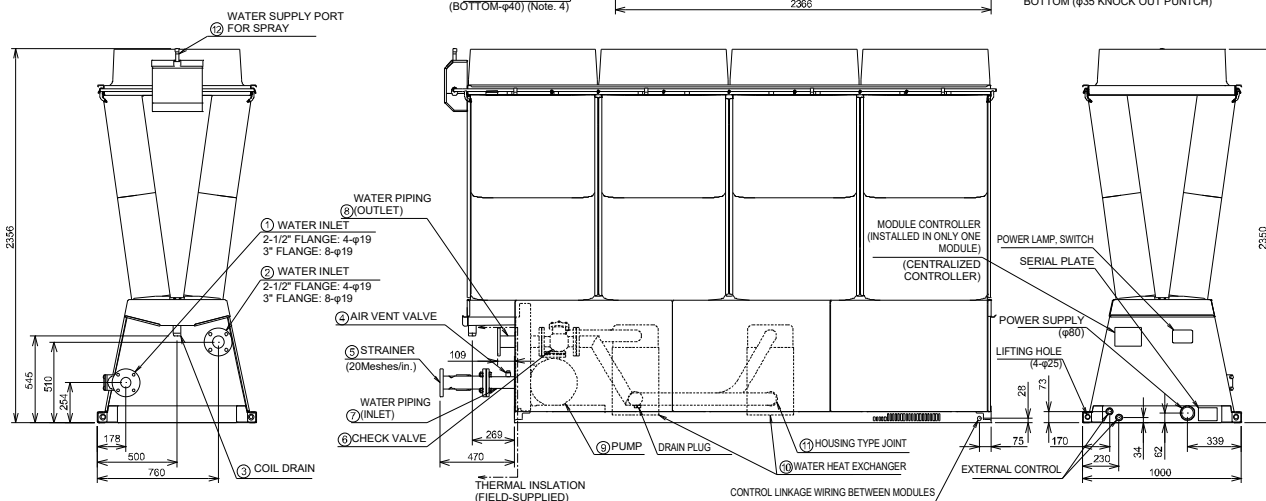
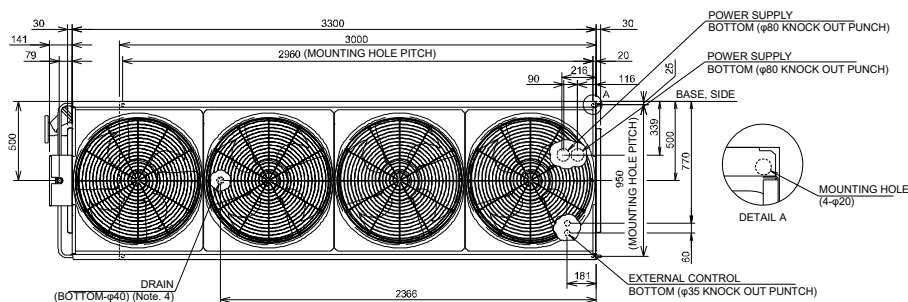

## Air heat exchanger sprinkler specifications

Amount of water sprinkled (L/min)	13.6 (per module)
Supply water pressure (MPa)	0.2
Water temperature range (°C)	10 to 30
Control system	When the outdoor air temperature is more than the operation start temperature and the compressor capacity is more than the operation start capacity, water is sprinkled continuously. When the outdoor air temperature is less than the operation end temperature or the compressor capacity is less than the operation end capacity, the operation ends.

## DN code list (HIF board in control box)

DN code	Functions	Description	Initial value	Variable range
61	Evaporative condenser operation start temperature [°C]	Outside air temperature that triggers operation	30	20 to 45
62	Evaporative condenser operation end temperature [°C] (difference from start temperature)	Operation ends if following value is less than stated value: evaporative condenser operation start outside air temperature - evaporative condenser operation end outside air temperature	2	1 to 10
63	Evaporative condenser operation start capacity [%]	Compressor capacity when operation starts (Note)	75	0 to 100
64	Capacity when evaporative condenser operation ends [%] (Difference with start capacity)	Operation ends if following value is less than stated value: evaporative condenser operation start compressor capacity - evaporative condenser operation end compressor capacity	5	0 to 100

Note: This is the value when the compressor frequency at rated capacity is 100%.

## Note on use of high EER type

Water piping work is to be carried out in accordance with the laws and regulations of the installed location.

- In terms of water quality standards, be sure to satisfy the condition of once-through water in cooling water system as stipulated by "Water Quality Guidelines for Cooling and Air Conditioning Devices" (JRA-GL-02-1994) of The Japan Refrigeration and Air Conditioning Industry Association.

### Water quality standard values of cooling water, chilled water, warm water, and supplementary water

	Item <sup>(1)(3)</sup>	Cooling water system	Tendency <sup>(2)</sup>	
		Once-through	Corrosion	Scale formation
		Once-through water		
Standard item	pH (25°C)	6.8 to 8.0	○	○
	Electrical conductivity (mS/m)(25°C) {μS/cm} (25°C) <sup>(1)</sup>	40 or less {400 or less}	○	○
	Chloride ion (mgCl/l)	50 or less	○	
	Sulphate ion (mgSO <sub>4</sub> <sup>2-</sup> /l)	50 or less	○	
	Acid consumption (pH4.8) (mgCaCO <sub>3</sub> /l)	50 or less		○
	Total hardness (mgCaCO <sub>3</sub> /l)	70 or less		○
	Calcium hardness (mgCaCO <sub>3</sub> /l)	50 or less		○
	Ionic silica (mgSiO <sub>2</sub> /l)	30 or less		○
Reference item	Iron (mgFe/l)	1.0 or less	○	○
	Copper (mgCu/l)	1.0 or less	○	
	Chloride ion (mgS <sup>2-</sup> /l)	Undetectable	○	
	Ammonium ion (mgNH <sub>4</sub> <sup>+</sup> /l)	1.0 or less	○	
	Residual chlorine (mgCl/l)	0.3 or less	○	
	Free carbon (mgCO <sub>2</sub> /l)	4.0 or less	○	
	Stability index	-	○	○

(1) Item names, term definitions, and units are based on JIS K 0101.

Units and values in brackets ( { } ) are conventional units provided for reference.

(2) A circle (○) in a cell indicates a factor related to corrosion or scale generation tendency.

(3) Supply and supplementary source water means tap water (water supply), industrial water, or groundwater. Purified water, grey water, and softened water are excluded.

(4) The above 15 items are representative factors of corrosion and scale impairment.

\* For details, refer to the "Water Quality Guidelines for Cooling and Air Conditioning Devices" (JRA-GL-02-1994) of The Japan Refrigeration and Air Conditioning Industry Association.

- To prevent the spray nozzle from becoming clogged with foreign matter, install a 50-mesh strainer in the main pipes as shown below.

#### Pipe layout example

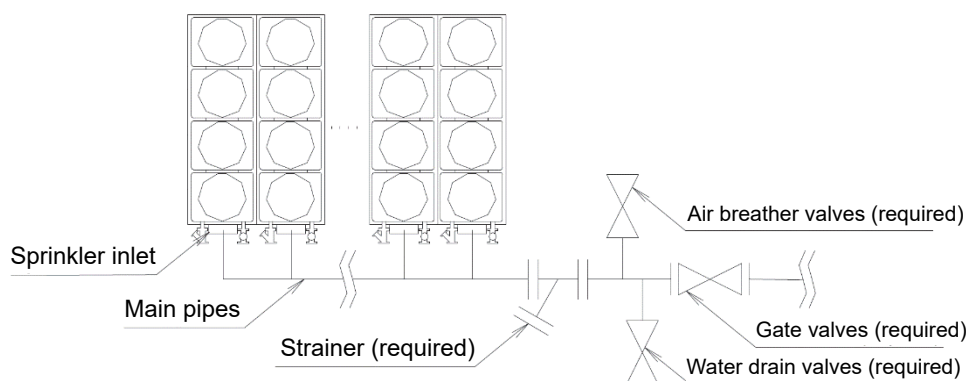

- Depending on the water quality, scales may adhere to the surface of the air heat exchanger. Scales not only degrade the performance of the air heat exchanger but may damage the air heat exchanger due to corrosion, so periodically check the scale adhesion condition on the surface of the air heat exchanger. If scales are found on the surface of the air heat exchanger, use a brush and low-pressure water to remove them. If necessary, install a water softener (procured locally) on the sprinkler inlet.

- As shown below, a manual flow rate adjustment valve is installed on the sprinkler inlet of each module. Adjust the flow rate so that the amount of water sprinkled on each module is almost uniform. If sufficient water pressure cannot be obtained, install a pressure pump (procured locally).

### Sprinkler inlet structure

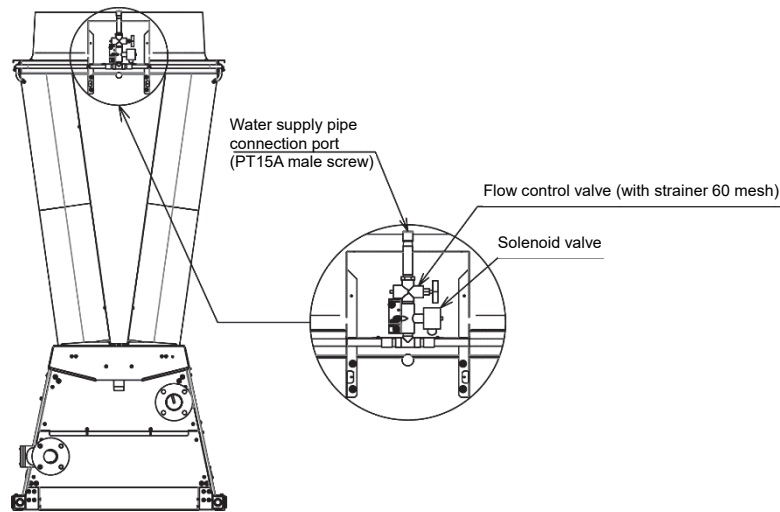

- If the water pressure is too high, provide a pressure reducing valve (provided locally) and a safety relief valve (provided locally), and adjust the water pressure.
- If water hammer causes vibration or water leakage, install a water hammer arrester (provided locally) as close to the sprinkler as possible.
- Also, if water sprinkled on the air heat exchanger surface is not uniform, the spray nozzle may be clogged with foreign matter. The spray nozzle of the sprinkler is shown in the figure below. Since the spray nozzle can be easily removed with a tool such as a spanner, wash it or replace the spray nozzle.  
Note: Spray nozzle A and spray nozzle B are different types of nozzles. Pay attention to their difference when installing.

### Sprinkler structure

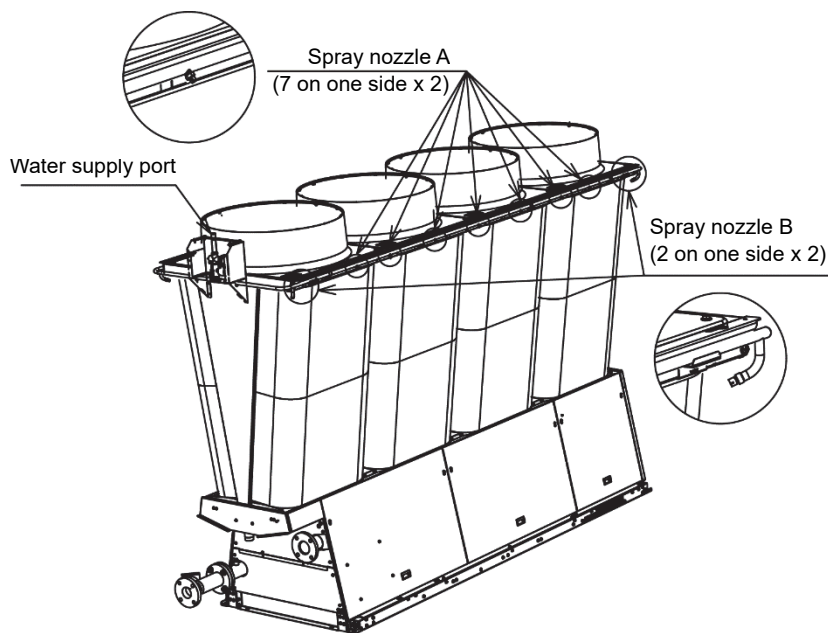

- Water from the sprinkler may be scattered around. Therefore, if necessary, apply waterproof treatment to the base surface, and provide drain channels and drain ports around the product so that drained water does not accumulate on the base surface.



# Maintenance and Inspection

## Maintenance and inspection contract

To make full use of the product functions, use the product correctly and perform maintenance and inspection periodically. It is highly recommended that you make a maintenance and inspection contract with a qualified installer, your dealer, or local Toshiba Carrier representative.

- To optimize your heat pump  
The quality of maintenance greatly affects the life and performance of your Heat Pump. Toshiba Carrier is ready to provide convenient, at-cost maintenance to users of our Heat Pump.
- Maintenance by trained technical specialists  
Periodic door-to-door services during season and maintenance before and after season are performed by trained technical specialists at the subscriber's expense.
- Requests and inquiries  
Contact your dealer or local Toshiba Carrier representative. More information provided on request.

## Prior to inspection

- Refer to "safety Precautions" on page 4.
- Make sure all relevant persons are aware before commencing work activities.
- The heat pump remote setting should be changed to "unit" and the operation should be stopped. The electrical supply should be isolated prior to working on the heat pump(s). The lock out, tag out procedure should be following to ensure the heat pump cannot be operated during the inspection activity.

During inspection, the appropriate signage should be displayed to make any persons in the area aware that work is taking place.

- Set the Remote/Unit switch on the operation panel of the module to Unit to stop the operation. Also, turn off all the circuit breakers, control circuits, fans and pump breakers in the power box before starting inspection.

## Periodic inspection items (Reference only)

Carrying out periodic inspections will minimize the chance of failure and prolong the life of the heat pump.

Note 1) Personal protective equipment to be used for inspection

Hardhat, safety boots, safety glasses, gloves and overalls or long sleeve shirt with safety trousers.  
Care should be taken when touching equipment that can still be hot to avoid the risk of burns.

Note 2) Maintenance cycle

The following reference values assume use in normal condition without frequent starts and stops, when the product is operating for 10 hours a day and 2,500 hours a year. If the product is used in the following environments, it is necessary to consider shortening the maintenance cycle.

- (1) Long operating time and frequent starts and stops
- (2) Place with large vibration and impact
- (3) Place with large variation in power supply (frequency, voltage, etc.)
- (4) Place with large variation in temperature and humidity
- (5) Place with poor ambient conditions (dust, salinity, machine oil, etc.)
- (6) Poor water quality of sprinkler (high-EER type)

The list below is provided for reference only. Inspection items and cycles need to be judged depending on the actual condition of the product. Contact our sales department for details.

Part name	Inspection description	Inspection method <small>Note 1)</small>	Criteria <Approximate guide>	Inspection cycle	Maintenance item	Maintenance cycle <small>Note 2)</small>	
Compressor	Operating noise, vibration	Visual, auditory, touch	No abnormal noise or vibration	Every year	Replace	20,000 hours	
	Smear mark	Visual	No smear mark		Replace		
	Insulation resistance	DC500V Megger	No problem in insulation resistance		Replace		
	Anti-vibration rubber	Deformation, elasticity	No negative effect on anti-vibration		Replace when deteriorated or hardened		
	Loose terminal, contact with wiring	Re-tighten, visual	No looseness or contact		Re-tighten		
Electric expansion valve	Operation check	Auditory, touch	No operation error or deformation	Every year	Replace when locked	20,000 hours	
2-way and 4-way solenoid valve	Operation/insulation performance	DC500V Megger	No problem in insulation resistance	Every year	Replace	20,000 hours	
	Corrosion, abnormal noise	Visual, auditory	No abnormal noise or corrosion		Replace		
Fusible plug	Appearance check	Visual	Soluble alloy position is normal	Every year	Replace	15,000 hours	
Pressure cut-off device	Operating pressure	LED display on HIF board	Operating with setpoint	Every year	Replace	25,000 hours	
Crankcase heater	Insulation	DC500V Megger	No problem in insulation resistance	Every year	Replace	8 years	
	Operation check	Contact with hands	No operation error				
Refrigerant system (strainer)	Clogging	Temperature difference between before/after inspection	No temperature difference or damage	Every year	Replace	20,000 hours	
Refrigerant system (vessel)	Corrosion of receiver/accumulator	Visual	No abnormal corrosion	Every year	Repair coating	20,000 hours	
Air heat exchanger <small>Note 8)</small>	Clogging, damage	Visual, wash	No clogging or damage	Every year	Wash	5 years	
	Gas leaks	Gas detector	No gas leaks		Repair, replace		
Water heat exchanger <small>Note 3), 5), 7)</small>	Dirt	Temperature/pressure difference	No abnormal temperature/pressure difference	Every year	Wash	5 years	
	Gas leaks	Gas detector	No gas leaks		Repair, replace		
Fan motor <small>Note 9)</small>	Operating noise, vibration	Visual, auditory	No abnormal noise or vibration	Every year	Replace	20,000 hours	
	Insulation resistance	DC500V Megger	No problem in insulation resistance				
Inverter (electrolytic capacitor)	Appearance of capacitor	Visual	No liquid leaks or deformation	Every year	Replace	5 years	
Cooling fan	Insulation resistance	DC500V Megger	No problem in insulation resistance	Every year	Replace	20,000 hours	
	Abnormal noise	Auditory	No abnormal noise or vibration				
Pressure sensor	Voltage value	Tester	Specific voltage	Every year	Replace	5 years	
	Exterior	Visual	No deformation				
Thermistor	Resistance	Tester	Specific resistance	Every year	Replace	5 years	
	Exterior	Visual	No deformation				
Control box (boards and electric parts)	Insulation resistance	DC500V Megger	No problem in insulation resistance	Every year	Replace	20,000 hours	
	Attachment of dust, etc.	Visual	No accumulation of dust, etc.		Clean, Replace		
Pump <small>Note 3), 5), 7), 10)</small>	Insulation resistance	DC500V Megger	No problem in insulation resistance	Every year	Replace	5 years	
	Operating noise, vibration	Visual, auditory, touch	No abnormal noise or vibration				
	Loose terminal, contact with wiring	Driver, visual	No looseness or contact				Correct
	Water leaks	Visual	No water leaks				Replace
Water piping <small>Note 3), 7)</small>	Water leaks	Visual	No water leaks	Every year	Re-tighten, repair	5 years	
	Air entrainment	Air vent, auditory	No noise of air entrainment		Air vent		
Strainer <small>Note 3), 5), 7)</small>	Dust clogging	Visual	No dirt or dust clogging	Every year	Clean	10 years	
Antifreeze <small>Note 6)</small>	Density	Antifreeze density	Specified density or higher	Every year	Control density	8 years	
	pH	Measure pH	pH7 to 10 (Antifreeze manufacturer criteria)		Replace		
Chilled (warm) water <small>Note 4)</small>	Water quality management	Water quality analysis	Criteria in JRA-02-1994	Every year	Control water quality	8 years	

Note 3) Water System Maintenance

The appropriate water processing should be carried out to ensure the prevention of corrosion, water scaling and also the pipework/equipment from freezing during the winter period. When draining the complete system, pipework, water heat exchanger and intend to stop the unit for a long period of time, the use of nitrogen gas to prevent internal corrosion is advised. In places where the temperature can drop below 0°C, the use of a specified antifreeze is permitted and should be circulated through the whole water system before draining any water. Care should be taken when choosing the antifreeze to ensure it does not corrode any parts of the water system.

Trained professionals should be used throughout maintenance activities and should be working to the relevant regulations and legislation of the water service provider.

Note 4) Water Quality Management

The brazing water heat exchanger is manufactured in a way that does not allow it to be dismantled, cleaned or have components replaced. Care should be taken in regards to the quality of water used in the water heat exchanger in order to prevent corrosion and water scaling.

When using a rust inhibitor, scale inhibitor, or any other type of agent, make sure that it is a type that will not corrode cast iron, stainless steel, copper, bronze, rubber and gasket.

Note 5) Flow rate management

An insufficient chilled (warm) water flow rate is one of the faults that can cause the freezing of the water plate heat exchanger. If the flow rate has been reduced, the following could be the cause; Clogged strainer, cavitation, faulty water pump etc. Also, measurement should be taken of the temperature difference and pressure differential between the water plate heat exchanger inlet and outlet. An increase of temperature or pressure differential beyond the specified range could indicate a drop in the water flow rate. If the case of a reduced flow rate, stop the system, rectify the fault and restart operation.

Note

If operation of a freeze protection device is triggered while operation is in progress, be sure to eliminate the cause before restarting operation. The plate heat exchanger is partially frozen at the moment that a freeze protection device operation is triggered. Attempting to restart operation without first eliminating the cause not only make it impossible to melt ice that is blocking the plate heat exchanger, repeated freezing will damage the plate heat exchanger, and lead to refrigerant leaks and the invasion of water into the refrigerant circuit.

Note 6) Antifreeze density management

When using antifreeze in the chilled (warm) water, use it only in the models and at the densities specified by the manufacturer. Do not use calcium chloride antifreeze, which will corrode the plate heat exchanger.

Antifreeze will absorb water in the air and lose density over time. Low antifreeze density can cause the water plate heat exchanger to freeze up, so it is important to minimize the amount of antifreeze surface area exposed to the atmospheric air. Also, measure the density of the antifreeze at regular intervals and replenish it as required to maintain the proper density.

Note 7) Precautions for freeze protection measures during winter

In locations where the winter temperatures can drop to 0°C or less, the pump installation location and the water piping should be taken into consideration.

In the cases where installation conditions or structural limitations make it impossible to locate the pump where it will prevent freezing or pipework where you cannot fully insulate, the previous steps should be carried out to protect the system against freezing.

- (1) Consider the installation position of pump freeze protection thermostat sensors at locations where the water temperature in the pump or piping drops the earliest to trigger pump operation.

(2) Add the specified amount of glycol anti freeze to the circulating water. The use of specified anti freeze is also permitted. Care should be taken when selecting the chemicals to ensure they do not corrode the water plate heat exchanger or pipework.

Note 8) Air heat exchanger clogging

Periodically inspect the air heat exchanger for clogging at regular intervals. If the coil is clogged, use a brush, a vacuum cleaner, pressurized air, or other means to remove dirt from between the fins. If heavily stained, remove the fan deck and apply low-pressure water from inside the coil. At this time, shut down the power and take care to avoid getting water on the fan motor and electrical components.

Note 9) Replacing the fan motor

The fan motor uses an oil-free bearing, so replenishment of lubricating oil is not required. If the noise level from the fan becomes too loud, the fan motor needs to be replaced.

Note 10) Pump Maintenance

The daily maintenance procedures for the water pump are shown on page 175 "Pump Maintenance".

Note 11) Refrigerant oil

This unit uses special refrigerant oil (RB74AF). Do not mix it with other oils.

Note 12) Refrigerant recovery and charging

This unit uses R32 refrigerant, which is a near-azeotropic mixture with an ozone depletion potential of 0. When charging the refrigerant, be sure to use R32 only. The table below shows enclosed capacities and global warming potential (GWP). In the event of a refrigerant leak, the systems refrigerant will need to be recovered and the leaks repaired. Once recovered, check for leaks, vacuum the system and then charge the system to the specified refrigerant amount. The system must be charged as a liquid and from the liquid line service port. Issues can arise when charging the system as a gas result in the refrigerant turning into a two phase mixture. composition changes are highly likely when charging as a gas so it is highly important to charge as a liquid.

Refrigerant			
Type	Number	Enclosed capacity (kg)	Global Warming Potential (GWP)
HFC	R32	35.2	675

Note

Never use anything other than the specified refrigerant (R32) when refilling or changing. If a refrigerant other than that specified is used, it could cause the heater to break or rupture and cause an injury.

Note 13) Disposing of heat pump

Ask a fluorocarbon recovery company when disposing of the unit in accordance with said Act.

Note 14) Relocation of heat pump

Ask your original dealer or local Toshiba Carrier representative for relocation work. Inadequate installation may cause malfunction, electric shock or fire.

# Water Heat Exchanger Maintenance

Scales can cause a drop in water heat exchanger capacity and a drop in the flow rate, which can lead to fracturing due to freezing. Because of this, regularly scheduled maintenance is required to prevent scaling.

- (1) Perform the checks described below before entering the operational season.
  - Perform a water quality test and confirm that the results are within standard.
  - Clean the strainer.
  - Confirm the water flow rate is to the specified required.
  - Confirm there are no operational problems (pressure, flow rate, entering/leaving temperature, etc.)
- (2) The brazing water heat exchanger is manufactured in a way that does not allow it to be dismantled and cleaned, so the below steps should be performed to clean it.
  - (a) A 5% solution of formic acid, citric acid, oxalic acid, acetic acid, or phosphoric acid can be used as an anti-scaling wash. Never use hydrochloric acid, sulphuric acid, nitric acid, or other strongly corrosive agents.
  - (b) Close the gate valves at the inlet and outlet of chilled (warm) water in the heat pump unit to prevent water from entering the unit.
  - (c) Drain water from the three drain plugs which are installed within each module. (See the Installation Manual for the position of each plug.)
  - (d) When water is drained completely, remove the clamp of water outlet, and remove downstream water heat exchanger outlet connection ((1) in the figure below) and the flange of water outlet ((2) in the figure below) to take out the pipes.
  - (e) Remove upstream water heat exchanger outlet connection ((3) in the figure below) and downstream water heat exchanger inlet connection ((4) in the figure below) to take out the pipes.
  - (f) Remove upstream water heat exchanger inlet connection ((5) in the figure below) and the flange at the internal pump discharging side ((6) in the figure below) to take out the pipes.
  - (g) Connect the circuit pipe used for the chemical treatment to the inlet and outlet of the plate heat exchanger, and fill the plate heat exchanger with cleaner at a temperature between 50°C and 60°C. Next, use the pump to circulate the chemical for two to five hours. The circulation time depends on the temperature of the chemical treatment and the scaling condition. The colour of the liquid being removed should be taken into account to determine how much scale is being removed.
  - (h) After circulating the chemical treatment, remove it from the plate heat exchanger. Next, fill the plate heat exchanger with an aqueous solution of 1 to 2% sodium hydroxide (NaOH) or sodium bicarbonate (NaHCO<sub>3</sub>). Circulate the solution for 15 to 20 minutes to neutralize.
  - (i) After neutralization is complete, very carefully and thoroughly rinse the interior of the plate heat exchanger with clean water.
  - (j) When using a commercially available cleaning agent, confirm beforehand that it is a cleaning liquid that does not corrode stainless steel or copper.
  - (k) For detailed information about cleaning procedures, contact the manufacturer of the cleaning agent.
  - (l) After cleaning, return the removed three water drain plugs and three water pipes to the original position.
- (3) After cleaning, make sure that there are no water leaks and that the unit is operating normally.

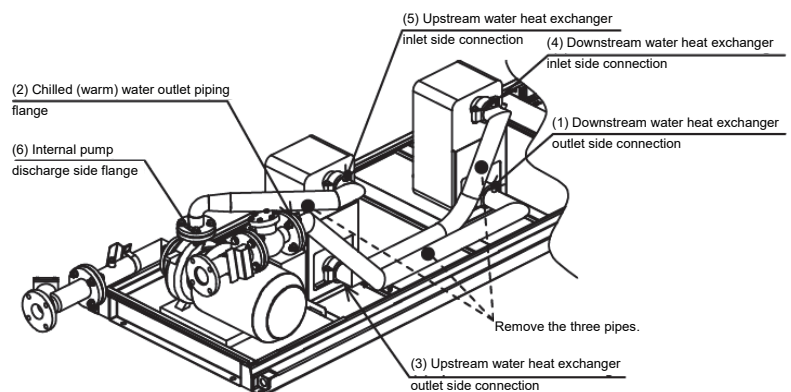

# Pump Maintenance

The following daily maintenance should be carried out for the water pump.

1. Check for any water leaks from the mechanical seals. (Mechanical seals lubricate a sliding surface with only a small amount of water leaks. However, water leaks are usually not found in visual inspection.)
2. Check for any unusual vibration or noise.
3. In the event of insufficient flow rate or any other irregularities noted during operation, this could be caused by a clogged strainer. In this case, the strainer should be cleaned.
4. The water pump is a replaceable part, the table below shows the replaceable parts available and the possible reasons to change the parts on the water pump.

Expendable parts	Inspection and repair guideline	Remarks
Mechanical seal	1 year	Replace when a leak occurs.
Ball bearing	3 years	Replace if an abnormal sound is produced.

Note 1: The rubber packing should be replaced every time the pump is dismantled.

# Water Quality Management

A brazing plate water heat exchanger is built in a way that does not allow dismantling and cleaning or component replacement.

Care must be exercised concerning the quality of the water used in a water heat exchanger in order to prevent corrosion and scaling.

The minimum requirements for the quality of water used in a plate water heat exchanger are those stipulated by the "Water Quality Guidelines for Cooling and Air Conditioning Devices" (JRA-GL-02-1994) of The Japan Refrigeration and Air Conditioning Industry Association.

When using a rust inhibitor, scale inhibitor, or any other type of agent, make sure that it is a type that will not corrode cast iron, stainless steel, copper, bronze, rubber and gasket.

## Water quality standard values of chilled (warm) water and supplementary water

Item <sup>(1) (6)</sup>	Cooling water system <sup>(4)</sup>			Chilled water system		Warm water system <sup>(3)</sup>				Tendency <sup>(2)</sup>	
	Circulation		Once-through			Low-grade medium temperature water system		High-grade medium temperature water system			
	Circulation water	Make up water	Once-through water	Circulation [20°C or lower]	Make up water	Circulation water [Greater than 20°C, less than 60°C]	Make up water	Circulation water [Greater than 60°C, less than 90°C]	Make up water	Corrosion	Scale formation
pH (25°C)	6.5 to 8.2	6.0 to 8.0	6.8 to 8.0	6.8 to 8.0	6.8 to 8.0	7.0 to 8.0	7.0 to 8.0	7.0 to 8.0	7.0 to 8.0	○	○
Electrical conductivity (mS/m)(25°C) {μS/cm} (25°C) <sup>(1)</sup>	80 or less {800 or less}	30 or less {300 or less}	40 or less {400 or less}	40 or less {400 or less}	30 or less {300 or less}	30 or less {300 or less}	30 or less {300 or less}	30 or less {300 or less}	30 or less {300 or less}	○	○
Chloride ion (mgCl/l)	200 or less	50 or less	50 or less	50 or less	50 or less	50 or less	50 or less	30 or less	30 or less	○	
Sulphate ion (mgSO <sub>4</sub> <sup>2-</sup> /l)	200 or less	50 or less	50 or less	50 or less	50 or less	50 or less	50 or less	30 or less	30 or less	○	
Acid consumption (pH4.8) (mgCaCO <sub>3</sub> /l)	100 or less	50 or less	50 or less	50 or less	50 or less	50 or less	50 or less	50 or less	50 or less		○
Total hardness (mgCaCO <sub>3</sub> /l)	200 or less	70 or less	70 or less	70 or less	70 or less	70 or less	70 or less	70 or less	70 or less		○
Calcium hardness (mgCaCO <sub>3</sub> /l)	150 or less	50 or less	50 or less	50 or less	50 or less	50 or less	50 or less	50 or less	50 or less		○
Ionic silica (mgSiO <sub>2</sub> /l)	50 or less	30 or less	30 or less	30 or less	30 or less	30 or less	30 or less	30 or less	30 or less		○
Iron (mgFe/l)	1.0 or less	0.3 or less	1.0 or less	1.0 or less	0.3 or less	1.0 or less	0.3 or less	1.0 or less	0.3 or less	○	○
Copper (mgCu/l)	0.3 or less	0.1 or less	1.0 or less	1.0 or less	0.1 or less	1.0 or less	0.1 or less	1.0 or less	0.1 or less	○	○
Chloride ion (mgS <sup>2-</sup> /l)	Undetectable	Undetectable	Undetectable	Undetectable	Undetectable	Undetectable	Undetectable	Undetectable	Undetectable	○	
Ammonium ion (mgNH <sub>4</sub> <sup>+</sup> /l)	1.0 or less	0.1 or less	1.0 or less	1.0 or less	0.1 or less	0.3 or less	0.1 or less	0.1 or less	0.1 or less	○	
Residual chlorine (mgCl/l)	0.3 or less	0.3 or less	0.3 or less	0.3 or less	0.3 or less	0.25 or less	0.3 or less	0.1 or less	0.3 or less	○	
Free carbon (mgCO <sub>2</sub> /l)	4.0 or less	4.0 or less	4.0 or less	4.0 or less	4.0 or less	0.4 or less	0.4 or less	0.4 or less	4.0 or less	○	
Stability index	6.0 to 7.0	-	-	-	-	-	-	-	-	○	○

Note (1) Item names, term definitions, and units are in accordance with JIS K 0101. Units and values in brackets ( { } ) are conventional units provided for reference.

(2) A circle (○) in a cell indicates a factor related to corrosion or scaling.

(3) High temperatures (40°C or higher) generally result in a striking increase in corrosion. In the case of ferrous metal materials in particular, if such material will come into direct contact with the water it is best to perform effective corrosion protection measures, such as the addition of an anti-corrosion agents, deterioration, etc.

(4) Cooling water systems that uses a sealed cooling tower, closed-circuit circulation water and other supplementary water depend on warm water system water quality standards, while sprinkler water and other supplementary water depend on circulative water system water quality standards.

(5) Supply and supplementary source water means tap water (water supply), industrial water, or ground water. Purified water, grey water, and softened water are not included.

(6) The above 15 items show representative factors of corrosion and scale impairment.

※ For details, refer to the "Water Quality Guidelines for Cooling and Air Conditioning Devices" (JRA-GL-02-1994) of The Japan Refrigeration and Air Conditioning Industry Association.

# Precautions When Operation Is Stopped

## Short term break

Heat source is not in operation daily or up to a week

- (1) Press the RUN/STOP button on the module controller to stop the chiller units operation.
- (2) When external water pumps are used and are controlled by group input / output signals, the water pump will begin its stopping process automatically<sup>Note</sup> (For water pumps not using group input / output signals, ensure the stopping procedure is performed<sup>Note</sup>).  
When the chiller has a built in inverter driven water pump, the water pump will begin its stopping process automatically.<sup>Note</sup>
- (3) The power supply to the chiller should never be turned off. The crankcase heater control for the heating of refrigerant oil and freeze protection control for the water pump are still active, even when the chiller is in the stop condition.

In the case of a system using an external pump and set up for group operation, ensure the water pumps power supply is never turned off, as the freeze protection control is still active when in its stop condition.

- (4) To reduce the risk of the water pipework freezing, the adding of antifreeze chemicals are permitted or the operation of the water pump should be performed. The antifreeze chemicals used should be in accordance to European standards and cautions should be taken ensure the plate heat exchanger or pipework will not corrode.

Note) Time of the stopping operation changes in accordance to the low pressure control for each circuit (15 seconds is the minimum).

## Long term break

Heat source is not in operation for a week or more

- (1) Press the RUN/STOP button on the module controller to stop the chiller units operation.
- (2) When external water pumps are used and are controlled by group input / output signals, the water pump will begin its stopping process automatically<sup>Note</sup> (For water pumps not using group input / output signals, ensure the stopping procedure is performed<sup>Note</sup>).  
When the chiller has a built in inverter driven water pump, the water pump will begin its stopping process automatically.<sup>Note</sup>
- (3) On completion of the pump succeeding operation <sup>Note</sup>, turn off the power supply of the heat pump and external water pump. (Also turn off the heat pump for energy saving since the crankcase heater remains powered on.)
- (4) Once the chiller has completed the stop operation<sup>Note</sup>, the power supply to the chiller should be turned off. If applicable, the external water pump(s) power supply should also be turned off.

Note) Time of the stopping operation changes in accordance to the low pressure control for each circuit (15 seconds is the minimum).

Note

Before the long-term operation stop, either drain water in the water piping or replace anti-freeze. Leaving water inside the piping or mechanism creates the risk of damage to the equipment should freezing of the water occur during winter.

## Notes on starting after long-term stop of operation

- (1) The power supply to the chiller needs to be turned on for at least 12 hours prior to operating the chiller, this is to ensure the crankcase heater warms the refrigerant oil. Failure to warm the refrigerant oil could cause an irregular start up and damage the compressor.  
If the chiller is required to stop each day, the RUN/STOP button should be pressed with the power supply kept on.
- (2) On completion of the 12 hours refrigerant warming, the "Test Run" procedure should be carried out to begin operation.



# Troubleshooting

In the event that the USX Edge chiller should stop due to fault conditions, contact your local representative for details. Under no circumstance should you try and rectify the fault yourself. All faults should be rectified by a trained professional. The model name, error code and serial number will be required to investigate the fault.

The troubleshooting table below is an advisory and should not be taken as an error code.

Symptom		Check item
Pump/compressor does not start	Operation indicator does not light up	Is there a power interruption?
		Is the external power switch turned OFF?
		Is the operating mode (Unit/External/Remote) correct?
	Operation indicator lights up	Are any of the power box circuit breakers turned off?
		Is the module Unit/Remote switch set to Unit?
Pump is operating but compressor does not start		Is the leaving water temperature close to the set temperature?
		Has the compressor stopped for less than 2 minutes?
		Is operation pattern (temperature setpoint, etc.) set correctly?
		Is operation mode (cooling/heating) correct?
Pump is operating but water is not circulating		Are the valves inside the water piping system open?
		Is the air accumulated inside the water piping system?
		Is the water shared with other heat pump?
		Is the pressure of suction pipe negative? (Too much resistance for suction pipe)
Water is accumulating on the surface of the water pump.		Are there any water leaks visible when carrying out the visible inspection?
Water drains from the bottom of the chiller base, causing the surface around the chiller to get wet.		Is there condensation occurring inside the chiller? Ensure water is drained as required.
Enclosures or the surface around the chillers are getting wet.		Is the sprinkler operating or has the sprinkler operated? (The water sprayed will cover the surface of the air heat exchanger).
Water is draining from the coil drain pan pipework during cooling operation.		Is the sprinkler operating or has the sprinkler operated? (The water sprayed might not have evaporated therefore will be drained via the drain pan pipework).

Main troubleshooting examples are described from the next page.

- (Note 1) in the tables applies to the model having a built-in inverter pump only.
- (Note 2) in the tables applies to the heat pump module only.
- (Note 3) in the tables applies to the powerful heating type only.

Repairs require specialized technical expertise. Do not repair the equipment by yourself but contact your dealer or local Toshiba Carrier representative.

## Error code causes and solutions. – part 1

Error code (Hexadecimal)	Description	Cause	Required action
00	Normal	-	-
03	Open-phase failure	Open circuit condition or loose connection in power supply wiring.	Repair power wiring.
		PWM board error	Replace PWM board.
04	Abnormal output volt	EEV board error or blown fuse.	Replace EEV board.
05	Overcurrent for pump <sup>(Note 1)</sup>	Pump burnout and insulation deterioration	Replace pump.
		Contact and grounding error due to power line damage	Replace power line.
		Load fluctuations increased beyond tolerance.	Reduce fluctuations
		Incorrect inverter settings.	Review inverter setting.
		Misoperation due to noise	Take noise measure for control circuit, main circuit, and grounding.
06	Overvoltage for pump <sup>(Note 1)</sup>	Power supply voltage increased beyond specified limit.	Lower the power supply voltage.
		Surge voltage is mixed in the input voltage.	Eliminate surge voltage.
		Pump wiring incorrectly earthed.	Remove the grounding error.
		Incorrect inverter settings.	Review inverter setting.
		Misoperation due to noise	Take noise measure for control circuit, main circuit, and grounding.
07	Overload for pump <sup>(Note 1)</sup>	Large load	Reduce the load.
		Incorrect inverter settings.	Review inverter setting.
08	Overheating for pump <sup>(Note 1)</sup>	Large load	Reduce the load.
		Cooling fan error (pump inverter)	Replace cooling fan.
0A	Low voltage for pump <sup>(Note 1)</sup>	Large load	Reduce the load.
		Incorrect inverter settings.	Review inverter setting.
0C	Low voltage for pump <sup>(Note 1)</sup>	Open circuit condition or loose connection in power supply wiring.	Repair power wiring.
		Power supply voltage is too low.	Raise the power supply voltage.
		A power outage occurred	Repair the power supply
		Inverter internal circuit deterioration	Replace inverter.
		Insufficient power transformer capacity	Review power transformer capacity.
0D	Missing phase output <sup>(Note 1)</sup>	Open circuit condition or loose connection in output wiring.	Repair output wiring.
		Disconnection of pump winding	Replace pump.
		Inverter output transistor error	Replace inverter.
0E	Other abnormalities <sup>(Note 1)</sup>	(Check the LED operator display on the inverter.)	
0F	Communication err (P) <sup>(Note 1)</sup>	Open circuit condition or loose connection in communication line wiring.	Repair communication line.
		Inverter communication function error	Replace inverter.
		CPU board communication port error	Replace CPU board.
10	UC communication err	Open circuit condition or loose connection in communication line wiring.	Repair communication line.
		CPU board communication port error	Replace CPU board.
		Module controller error	Replace module controller.
12	Internal comm error	Open circuit condition or loose connection in communication line wiring.	Repair communication line.
		CPU board communication port error	Replace CPU board.
		EEV board error	Replace EEV board.
		Control transformer error	Replace power board.
		Blown fuse	Rectify fault and replace 16A fuse.
		Circuit breaker has tripped	Rectify fault and switch breaker back on.
1A	HumanIF comm error	Open circuit condition or loose connection in communication line wiring.	Repair communication line.
		Board communication port error	Replace board.
		Open circuit in wiring	Repair wiring.
1B	IO board comm error	Same as "Human IF communication error"	Same as "Human IF communication error"
20	Thermistor err EWT	Open circuit condition or loose connection in wiring.	Repair wiring.
		Thermistor error	Replace thermistor.
21	Thermistor err LWT	Same as "Thermistor problem (chilled (warm) water inlet temperature)"	Same as "Thermistor err EWT"
22	Thermistor err MWT	Same as "Thermistor problem (chilled (warm) water inlet temperature)"	Same as "Thermistor err EWT"
2E	RH sensor error <sup>(Note 3)</sup>	Open circuit condition or loose connection in wiring.	Repair wiring.
		Relative humidity sensor fault	Replace relative humidity sensor.
2F	Thermistor err OAT	Same as "Thermistor problem (chilled (warm) water inlet temperature)"	Same as "Thermistor err EWT"

Error code causes and solutions. – part 2

Error code (Hexadecimal)	Description	Cause	Required action
30	Thermistor error (compressor suction gas temperature)	Same as "Thermistor problem (chilled (warm) water inlet temperature)"	Same as "Thermistor problem (chilled (warm) water inlet temperature)"
31	Thermistor error (compressor suction gas temperature)	Same as "Thermistor problem (chilled (warm) water inlet temperature)"	Same as "Thermistor problem (chilled (warm) water inlet temperature)"
32	Thermistor error (coil gas temperature 1) <sup>(Note 2)</sup>	Same as "Thermistor problem (chilled (warm) water inlet temperature)"	Same as "Thermistor problem (chilled (warm) water inlet temperature)"
33	Thermistor error (coil gas temperature 2) <sup>(Note 2)</sup>	Same as "Thermistor problem (chilled (warm) water inlet temperature)"	Same as "Thermistor problem (chilled (warm) water inlet temperature)"
35	Thermistor error (reactor humidity)	Same as "Thermistor problem (chilled (warm) water inlet temperature)"	Same as "Thermistor problem (chilled (warm) water inlet temperature)"
40	High-pressure sensor error	Open circuit condition or loose connection in control wiring. Pressure sensor error	Repair wiring. Replace pressure sensor.
41	Low-pressure sensor error	Same as "High-pressure sensor error"	Same as "High-pressure sensor error"
4A	Chilled (warm) water inlet pressure sensor error	Same as "High-pressure sensor error"	Same as "High-pressure sensor error"
4B	Chilled (warm) water outlet pressure sensor error	Same as "High-pressure sensor error"	Same as "High-pressure sensor error"
4C	Pump suction press sensor err	Same as "High-pressure sensor error"	Same as "High-pressure sensor error"
50	Freeze protection	Rapid load fluctuation	Adjust water piping system (bypass control, etc.).
		Clogged strainer	Clean strainer.
		Pump error	Replace pump.
		Inverter error	Replace inverter.
		Air accumulation	Release air.
		The water heat exchanger is dirty	Clean the water heat exchanger (chemical cleaning).
		Water temperature thermistor error value	Repair wiring, change thermistor.
51	High temperature prevention	Same as "Freeze protection"	Same as "Freeze protection"
52	Low flow rate protection	Rapid load fluctuation	Adjust water piping system (bypass control, etc.)
		Clogged strainer	Clean strainer
		Pump error	Replace pump
		Inverter error	Replace inverter
		Air accumulation	Release air
		The water heat exchanger is dirty	Clean the water heat exchanger (chemical cleaning)
		Water pressure sensor error value	Repair wiring, change water pressure sensor
53	Water temperature inlet/outlet reversal	The inlet and outlet pipes have been reversed. Applicable water temperature thermistor error value	Repair the inlet and outlet pipes. Repair wiring / change thermistor.
5A	Subnormal pump suction press	Open circuit in wiring, loose terminal	Repair the wiring.
		Pressure sensor fault	Replace the pressure sensor.
5B	Chilled (warm) water pressure error	Rapid pressure fluctuation	Adjust water piping system (bypass control, etc.).
		Water pressure sensor error value	Repair wiring / change sensor.
60	High pressure fault	Fan motor error (cooling mode).	Replace fan motor.
		Fan IPDU board error (cooling mode).	Replace fan IPDU board.
		Short circuit (cooling mode).	Remove cause of short circuit.
		The air heat exchanger is dirty.	Clean the air heat exchanger.
		Water temperature increased/decreased rapidly (heating mode).	Same as "High temperature prevention"
		Overcharge of refrigerant after maintenance	Charge unit to specified refrigerant amount.
		Four-way valve error	Same as "Four-way valve error"
61	Low pressure error 1	Refrigerant leak	Repair leaks and charge refrigerant.
		Expansion valve error	Replace expansion valve.
		Water temperature increased/decreased rapidly (cooling mode).	Same as "Freeze protection"
		Rapid increase / decrease in water flow rate.	Same as "Low flow rate protection"
		Fan motor error (heating mode).	Replace fan motor.
		Short circuit (heating mode).	Remove cause of short circuit.
		Low-pressure sensor error value	Repair wiring / change sensor.
62	Low pressure error 2	Four-way valve error Insufficient antifreeze concentration.	Same as "Four-way valve error" Replenish antifreeze
63 (continued)	Compressor discharge gas overheat error	Refrigerant leak	Repair leaks and charge refrigerant.
		Expansion valve error	Replace expansion valve.
		Water temperature increased/decreased rapidly (cooling mode).	Same as "Freeze protection"
		Rapid increase / decrease in water flow rate.	Same as "Low flow rate protection"
		Low-pressure sensor error value	Repair wiring / change sensor.
		Four-way valve error	Same as "Four-way valve error"
		Insufficient antifreeze concentration.	Replenish antifreeze
63 (continued)	Compressor discharge gas overheat error	Refrigerant leak	Repair leaks and charge refrigerant.
		Expansion valve error	Replace expansion valve.
		Compressor error	Replace compressor.

Error code causes and solutions. – part 3

Error code (Hexadecimal)	Description	Cause	Required action
63 (continued)	Abnormal DGT	The air heat exchanger is dirty (cooling mode)	Clean the air heat exchanger.
		The water heat exchanger is dirty (heating mode)	Clean the water heat exchanger (chemical cleaning).
		Overcharge of refrigerant after maintenance	Charge unit to specified refrigerant amount.
		Discharge gas thermistor error value	Repair wiring / change thermistor.
		Equalizer valve error	Same as "Equalizer valve error"
64	Abnormal SGT	Refrigerant leak	Repair leaks and charge refrigerant.
		Expansion valve error	Replace expansion valve.
		Water temperature increased/decreased rapidly (cooling mode).	Same as "Low Water [T] Cutout"
		Sharp fluctuation in flow rate	Same as "Low flow cutout"
		Suction gas thermistor error value	Repair wiring / change thermistor.
		Insufficient antifreeze concentration.	Replenish antifreeze
65	Refrigerant shortage	Refrigerant leak	Repair leaks and charge refrigerant.
		High-pressure sensor error value	Repair wiring / change sensor.
66	Comp. out of range	Load fluctuations are too large	Reduce fluctuations
		Outside air temperature is outside the specified working range.	Operate the unit within the specified working range.
		The chilled (warm) water temperature is outside the working range.	Operate the unit within the specified working range.
		The power supply's voltage or frequency is outside the specified working range.	Operate the unit within the specified working range.
		Strong wind	Install windbreak and window baffle.
		Short circuit	Remove cause of short circuit.
67	Compressor unstarted failure	Compressor fault	Replace the compressor.
		Incorrect or loose wiring on the IPDU board of the compressor terminal	Repair the wiring.
		Incorrect wiring or loose wiring of the compressor terminal	Repair the wiring.
		The power supply (voltage, frequency) is outside the working range.	Operate the unit within the working range.
71	Exp. valve1 abnormal	Open circuit in control wiring, loose terminal	Repair the control wiring.
		Expansion valve error	Replace expansion valve.
		Open circuit condition or loose connection in control wiring.	Repair the control wiring.
		Suction gas thermistor error value	Repair wiring / change thermistor.
		Coil gas thermistor error value (heat pump only)	Repair wiring / change thermistor.
		Low-pressure sensor error value	Repair wiring / change sensor.
72	Exp. valve2 abnormal	EEV board error	Replace EEV board.
		Same as "Exp. valve1 abnormal"	Same as "Exp. valve1 abnormal"
73	4way valve abnormal <sup>(Note 2)</sup>	Four-way valve main unit error	Replace four-way valve main unit.
		Four-way valve coil error	Replace four-way valve coil.
		Open circuit condition or loose connection in control wiring.	Repair the control wiring.
		Thermistor error value (discharge, suction, coil)	Repair wiring / change thermistor.
		EEV board error	Replace EEV board.
		Outside air temperature is outside the specified working range.	Operate the unit within the specified working range.
74	Equalize valve error	Equalizer valve main unit error	Replace equalizer valve main unit.
		Equalizer valve coil error	Replace equalizer valve coil.
		Open circuit condition or loose connection in control wiring.	Repair the control wiring.
		High-pressure and low-pressure sensor error value	Repair wiring / change sensor.
		EEV board error	Replace EEV board.
75	Refrig injection line failure	Injection 2-way valve body or coil fault	Replace the injection 2-way valve body or coil.
		Injection expansion valve body or coil fault	Replace the injection 2-way expansion valve or coil.
		EEV board fault	Replace the EEV board.
		Open circuit in control wiring, loose terminal	Repair the control wiring.
		Clogged strainer	Replace the strainer.
		Check valve operation fault	Replace the check valve.
7A	Cooling fan abnormal	Cooling fan fault	Replace cooling fan.
		Open circuit condition or loose connection in control wiring.	Repair the control wiring.
		Heat sink sensor error value	Repair wiring / change sensor.
		EEV board error	Replace EEV board.
A0	COMP IGBT short	Ventilation path obstructed.	Clear ventilation path.
		Compressor error	Replace compressor.
		Compressor PWM board error	Replace PWM board.
		Compressor drive module error	Replace compressor drive module.
		The power supply's voltage or frequency is outside the specified working range.	Operate the unit within the specified working range.
		Open circuit condition or loose connection in control wiring.	Repair the control wiring.

Error code causes and solutions. – part 4

Error code (Hexadecimal)	Description	Cause	Required action
A1	COMP detct crcit err	PWM board error	Replace PWM board
		The power supply's voltage or frequency is outside the specified working range.	Operate the unit within the specified working range.
		Open circuit condition or loose connection in control wiring.	Repair the control wiring.
A2	COMP Crnt snsr err	PWM board error	Replace PWM board
		Open circuit condition or loose connection in control wiring.	Repair the control wiring.
A3	COMP Mortor Lock	Compressor error	Replace compressor.
		Miswiring and wiring disconnection of PWM board	Repair wiring.
		Incorrect wiring or disconnection of compressor terminal	Repair wiring.
		The power supply's voltage or frequency is outside the specified working range.	Operate the unit within the specified working range.
		Open circuit condition or loose connection in control wiring.	Repair the control wiring.
		Overload	Improve working conditions to reduce the load.
A4	COMP Breakdown	Compressor error	Replace compressor.
		PWM board error	Replace PWM board
		The power supply's voltage or frequency is outside the specified working range.	Operate the unit within the specified working range.
		Open circuit condition or loose connection in control wiring.	Repair the control wiring.
		Load fluctuations are too large	Reduce fluctuations
		Cooling fan error	Replace cooling fan.
		A power outage occurred	Repair the power supply
		Overload	Improve working conditions to reduce the load.
A5	COMP Other error	Compressor error	Replace compressor.
		IPDU board error	Replace IPDU board
		The power supply's voltage or frequency is outside the specified working range.	Operate the unit within the specified working range.
		Open circuit condition or loose connection in control wiring.	Repair the control wiring.
		A power outage occurred	Repair the power supply.
		Overload	Improve working conditions to reduce the load.
AC	Heatsink overheat	Cooling fan error	Replace cooling fan.
		Open circuit condition or loose connection in control wiring.	Repair the control wiring.
		Heat sink sensor error value	Repair wiring / change sensor.
		PWM board error	Replace PWM board
AD	Heatsink sensor err	Temperature sensor error	Replace temperature sensor.
		PWM board error	Replace PWM board
		Open circuit condition or loose connection in control wiring.	Repair the control wiring.
AF	COMP IPDU comm error	Open circuit condition or loose connection in communication line wiring.	Repair communication line.
		Failure of communication port on EEV board	Replace EEV board
		PWM board error	Replace PWM board
		Blown 16A fuse (400 V specification only)	Rectify fault and replace 16A fuse.
		Power rectifier error	Replace rectifier.
		Open circuit condition in wiring	Repair wiring.
B0	COMP abnormal volt	The power supply's voltage or frequency is outside the specified working range.	Operate the unit within the specified working range.
		PWM board error	Replace PWM board.
		Open circuit condition or loose connection in control wiring.	Repair the control wiring.
		A power outage occurred	Repair the power supply.
		Circuit breaker has tripped	Rectify fault and switch breaker back on.
		Rectifier for compressor error	Replace rectifier.
		Blown fuse (400 V specification only)	Rectify fault and replace fuse.
		Magnet switch breakdown	Replace magnet switch and repair wiring.
B1	COMP IPDU board err	The power supply's voltage or frequency is outside the specified working range.	Operate the unit within the specified working range.
		PWM board error	Replace PWM board.
		Open circuit condition or loose connection in control wiring.	Repair the control wiring.

Error code causes and solutions. – part 5

Error code (Hexadecimal)	Description	Cause	Required action
C2	FAN overload	Fan motor error	Replace fan motor.
		The power supply's voltage or frequency is outside the specified working range.	Operate the unit within the specified working range.
		Open circuit condition or loose connection in control wiring.	Repair the control wiring.
		Load fluctuations due to strong wind	Reduce fluctuations
		Insufficient space for the suction and discharge of air.	Ensure enough space has been provided for the suction and discharge of air.
C4	FAN motor Breakdown	Fan motor error	Replace fan motor.
		The power supply's voltage or frequency is outside the specified range.	Operate the unit within the specified working range.
		Open circuit condition or loose connection in control wiring.	Repair the control wiring.
		Load fluctuations due to strong wind	Reduce fluctuations
		A power outage occurred	Repair the power supply
		Insufficient space for the suction and discharge of air.	Ensure enough space has been provided for the suction and discharge of air.
C5	FAN Synchronize err	Fan motor error	Replace fan motor.
		The power supply's voltage or frequency is outside the specified range.	Operate the unit within the specified working range.
		Open circuit condition or loose connection in control wiring.	Repair the control wiring.
		A power outage occurred	Repair the power supply
		Strong wind	Install windbreak and window baffle.
		Insufficient space for the suction and discharge of air.	Ensure enough space has been provided for the suction and discharge of air.
C6	FAN ctrl board err	Fan motor error	Replace fan motor.
CC	FAN Heatsink heating	Fan motor error	Replace fan motor.
		The power supply's voltage or frequency is outside the specified range.	Operate the unit within the specified working range.
		Insufficient space for the suction and discharge of air.	Ensure enough space has been provided for the suction and discharge of air.
		Open circuit condition or loose connection in control wiring.	Repair the control wiring.
CD	FAN phase loss	Fan motor error	Replace fan motor.
		Open circuit condition or loose connection in control wiring.	Repair the control wiring.
CE	FAN abnormal voltage	Fan motor error	Replace fan motor.
		The power supply's voltage or frequency is outside the specified range.	Operate the unit within the specified working range.
		A power outage occurred	Repair the power supply
		Circuit breaker has tripped	Rectify fault and switch breaker on.
		Open circuit condition or loose connection in control wiring.	Repair the control wiring.
CF	FAN IPDU comm error	Fan motor error	Replace fan motor.
		Open circuit condition or loose connection in communication line wiring.	Repair communication line.
		CPU board communication port error	Replace CPU board.
		Disconnection of communication wiring	Repair communication wiring.
F0	Converter error	Compressor IPDU board error	Replace the IPDU board.
		The power supply's voltage or frequency is outside the specified range.	Operate the unit within the specified working range.
		CT sensor error	Replace CT sensor.
		Disconnection of control wiring	Repair the control wiring.
F1	DIPSW setting error	DIP SW incorrectly set	Check DIP SW setting.

## ■ Declaration of Conformity

Manufacturer: Toshiba Carrier Corporation  
1300-3 Kamo, Kikugawa-shi, Shizuoka-ken, 439-0031 JAPAN

Authorized Representative/  
TCF holder: None  
Toshiba EMEA Engineering Director  
Toshiba Carrier UK Ltd.  
Porsham Close, Belliver Industrial Estate  
PLYMOUTH, Devon, PL6 7DB  
United Kingdom

Hereby declares that the machinery described below:

Generic Denomination: Air Heat Source Heat Pump Unit

Model/type: RUAGP421HL8E, RUAGP421HLN8E, RUAGP421CL8E, RUAGP421CLN8E  
RUAGP421H18E, RUAGP421H1N8E, RUAGP421C18E, RUAGP421C1N8E  
RUAGP421H28E, RUAGP421H2N8E, RUAGP421C28E, RUAGP421C2N8E  
RUAGP421H38E, RUAGP421H3N8E, RUAGP421C38E, RUAGP421C3N8E  
RUAGP421H58E, RUAGP421H5N8E, RUAGP421C58E, RUAGP421C5N8E  
RUAGP421H78E, RUAGP421H7N8E, RUAGP421C78E, RUAGP421C7N8E  
RUAGP421HLR8E, RUAGP421HLNR8E, RUAGP421CLR8E  
RUAGP421CLNR8E, RUAGP421H2R8E, RUAGP421H2NR8E  
RUAGP421C2R8E, RUAGP421C2NR8E, RUAGP421H3R8E  
RUAGP421H3NR8E, RUAGP421C3R8E, RUAGP421C3NR8E  
RUAGP421H5R8E, RUAGP421H5NR8E, RUAGP421C5R8E  
RUAGP421C5NR8E, RUAGP421H7R8E, RUAGP421H7NR8E  
RUAGP421C7R8E, RUAGP421C7NR8E, RUAGP511HL8E  
RUAGP511HLN8E, RUAGP511CL8E, RUAGP511CLN8E  
RUAGP511H18E, RUAGP511H1N8E, RUAGP511C18E, RUAGP511C1N8E  
RUAGP511H28E, RUAGP511H2N8E, RUAGP511C28E, RUAGP511C2N8E  
RUAGP511H38E, RUAGP511H3N8E, RUAGP511C38E, RUAGP511C3N8E  
RUAGP511H58E, RUAGP511H5N8E, RUAGP511C58E, RUAGP511C5N8E  
RUAGP511H78E, RUAGP511H7N8E, RUAGP511C78E, RUAGP511C7N8E  
RUAGP511HLR8E, RUAGP511HLNR8E, RUAGP511CLR8E  
RUAGP511CLNR8E, RUAGP511H2R8E, RUAGP511H2NR8E  
RUAGP511C2R8E, RUAGP511C2NR8E, RUAGP511H3R8E  
RUAGP511H3NR8E, RUAGP511C3R8E, RUAGP511C3NR8E  
RUAGP511H5R8E, RUAGP511H5NR8E, RUAGP511C5R8E  
RUAGP511C5NR8E, RUAGP511H7R8E, RUAGP511H7NR8E  
RUAGP511C7R8E, RUAGP511C7NR8E, RUAGP561HL8E  
RUAGP561HLN8E, RUAGP561CL8E, RUAGP561CLN8E, RUAGP561H28E  
RUAGP561H2N8E, RUAGP561C28E, RUAGP561C2N8E, RUAGP561H38E  
RUAGP561H3N8E, RUAGP561C38E, RUAGP561C3N8E, RUAGP561H58E  
RUAGP561H5N8E, RUAGP561C58E, RUAGP561C5N8E, RUAGP561H78E  
RUAGP561H7N8E, RUAGP561C78E, RUAGP561C7N8E, RUAGP561HLR8E  
RUAGP561HLNR8E, RUAGP561CLR8E, RUAGP561CLNR8E  
RUAGP561H3R8E, RUAGP561H3NR8E, RUAGP561C3R8E  
RUAGP561C3NR8E, RUAGP561H5R8E, RUAGP561H5NR8E  
RUAGP561C5R8E, RUAGP561C5NR8E, RUAGP561H7R8E  
RUAGP561H7NR8E, RUAGP561C7R8E, RUAGP561C7NR8E

RUAGP421FL8E, RUAGP421FLN8E, RUAGP421F18E, RUAGP421F1N8E  
 RUAGP421F28E, RUAGP421F2N8E, RUAGP421F38E, RUAGP421F3N8E  
 RUAGP421F58E, RUAGP421F5N8E, RUAGP421F78E, RUAGP421F7N8E  
 RUAGP421FLR8E, RUAGP421FLNR8E, RUAGP421F2R8E  
 RUAGP421F2NR8E, RUAGP421F3R8E, RUAGP421F3NR8E  
 RUAGP421F5R8E, RUAGP421F5NR8E, RUAGP421F7R8E  
 RUAGP421F7NR8E, RUAGP511FL8E, RUAGP511FLN8E, RUAGP511F18E  
 RUAGP511F1N8E, RUAGP511F28E, RUAGP511F2N8E, RUAGP511F38E  
 RUAGP511F3N8E, RUAGP511F58E, RUAGP511F5N8E, RUAGP511F78E  
 RUAGP511F7N8E, RUAGP511FLR8E, RUAGP511FLNR8E  
 RUAGP511F2R8E, RUAGP511F2NR8E, RUAGP511F3R8E  
 RUAGP511F3NR8E, RUAGP511F5R8E, RUAGP511F5NR8E  
 RUAGP511F7R8E, RUAGP511F7NR8E

Commercial name: Universal Smart X

Complies with the provisions of the “Machinery Directive 2006/42/EC” and the regulations transposing into national law

Complies with the provisions of the following harmonized standard: EN 378-2:2008+A1:2016

**Note**

This declaration becomes invalid if technical or operational modifications are introduced without manufacturer’s consent.

Information according to EMC Directive 2014/30/EU	
(Name of the manufacturer)	TOSHIBA CARRIER CORPORATION
(Address, city, country)	1300-3 Kamo, Kikugawa-shi, Shizuoka-ken 439-0031 JAPAN
(Name of the importer / Distributor in EU)	Toshiba Carrier UK Ltd.
(Address, city, country)	Porsham Close, Belliver Industrial Estate, PLYMOUTH, Devon, PL6 7DB United Kingdom